

Georgia Milestones

Assessment System



Study/Resource Guide for Students and Parents Grade 7



The Study/Resource Guides are intended to serve as a resource for parents and students. They contain practice questions and learning activities for each content area. The standards identified in the Study/Resource Guides address a sampling of the state-mandated content standards.

For the purposes of day-to-day classroom instruction, teachers should consult the wide array of resources that can be found at www.georgiastandards.org.

Study/Resource Guide

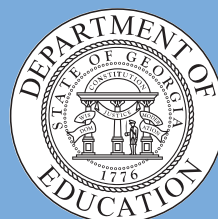

Table of Contents

THE GEORGIA MILESTONES ASSESSMENT SYSTEM	3
HOW TO USE THIS GUIDE	4
PREPARING FOR TAKING TESTS	5
OVERVIEW OF THE END-OF-GRADE ASSESSMENT	6
TYPES OF ITEMS	6
DEPTH OF KNOWLEDGE	7
ENGLISH LANGUAGE ARTS (ELA)	10
DESCRIPTION OF TEST FORMAT AND ORGANIZATION	10
CONTENT	10
ITEM TYPES	10
ENGLISH LANGUAGE ARTS (ELA) DEPTH OF KNOWLEDGE EXAMPLE ITEMS	11
ENGLISH LANGUAGE ARTS (ELA) CONTENT DESCRIPTION AND ADDITIONAL SAMPLE ITEMS ...	21
ENGLISH LANGUAGE ARTS (ELA) ADDITIONAL SAMPLE ITEM KEYS	50
ENGLISH LANGUAGE ARTS (ELA) SAMPLE SCORING RUBRICS AND EXEMPLAR RESPONSES ...	54
ENGLISH LANGUAGE ARTS (ELA) WRITING RUBRICS	62
MATHEMATICS	71
DESCRIPTION OF TEST FORMAT AND ORGANIZATION	71
CONTENT	71
ITEM TYPES	71
MATHEMATICS DEPTH OF KNOWLEDGE EXAMPLE ITEMS	72
MATHEMATICS CONTENT DESCRIPTION AND ADDITIONAL SAMPLE ITEMS	78
MATHEMATICS ADDITIONAL SAMPLE ITEM KEYS	103
MATHEMATICS SAMPLE SCORING RUBRICS AND EXEMPLAR RESPONSES	108
SCIENCE	117
DESCRIPTION OF TEST FORMAT AND ORGANIZATION	117
CONTENT	117
ITEM TYPES	117
SCIENCE DEPTH OF KNOWLEDGE EXAMPLE ITEMS	118
SCIENCE CONTENT DESCRIPTION AND ADDITIONAL SAMPLE ITEMS	121
SCIENCE ADDITIONAL SAMPLE ITEM KEYS	149
SOCIAL STUDIES	164
DESCRIPTION OF TEST FORMAT AND ORGANIZATION	164
CONTENT	164
ITEM TYPES	164
SOCIAL STUDIES DEPTH OF KNOWLEDGE EXAMPLE ITEMS	165
SOCIAL STUDIES CONTENT DESCRIPTION AND ADDITIONAL SAMPLE ITEMS	169
SOCIAL STUDIES ADDITIONAL SAMPLE ITEM KEYS	201
APPENDIX A: LANGUAGE PROGRESSIVE SKILLS, BY GRADE	206
APPENDIX B: CONDITION CODES	207

THE GEORGIA MILESTONES ASSESSMENT SYSTEM



Dear Student,

This **Georgia Milestones Grade 7 Study/Resource Guide for Students and Parents** is intended as a resource for parents and students. It contains sample questions and helpful activities to give you an idea of what test questions look like on Georgia Milestones and what the Grade 7 End-of-Grade (EOG) assessment covers.

These sample questions are fully explained and will tell you why each answer is either correct or incorrect.

Get ready—open this guide—and get started!

HOW TO USE THIS GUIDE

Let's get started!

* **Get it together!**

- This guide
- Pen or pencil
- Highlighter
- Paper



* **Gather materials**

- Classroom notebooks
- Textbooks

* **Study space**

- Find a comfortable place to sit.
- Use good lighting.
- Time to focus—no TV, games, or phones!

* **Study time**

- Set aside some time after school.
- Set a goal—how long are you going to study?
- Remember—you cannot do this all at one time.
- Study a little at a time, every day.

* **Study buddy**

- Work with a friend, sister, brother, parent—anyone who can help!
- Ask questions—it is better to ask now and get answers.
- Make sure you know what you need to do—read the directions before you start.
- Ask your teacher if you need help.

* **Test-taking help**

- Read each question and all of the answer choices carefully.
- Be neat—use scratch paper.
- Check your work!

PREPARING FOR TAKING TESTS

Getting ready!



Here are some ideas to think about before you take a test.

- Get plenty of rest and eat right. Take care of your body and your mind will do the rest.
- If you are worried about a test, don't be. Talk with a teacher, parent, or friend about what is expected of you.
- Review the things you have learned all year long. Feel good about it.
- Remember that a test is just one look at what you know. Your class work, projects, and other tests will also show your teachers how much you have learned throughout the year.

Try your best!

OVERVIEW OF THE END-OF-GRADE ASSESSMENT

What is on the End-of-Grade Assessment?

- * English Language Arts (ELA)
- * Mathematics
- * Science
- * Social Studies

TYPES OF ITEMS

- * **Selected-response items**—also called multiple-choice
 - English Language Arts (ELA), Mathematics, Science, and Social Studies
 - There is a question, problem, or statement that is followed by four answer choices.
 - There is only ONE right answer, so read EACH answer choice carefully.
 - Start by eliminating the answers that you know are wrong.
 - Then look for the answer that is the BEST choice.

- * **Constructed-response items**
 - English Language Arts (ELA) and Mathematics only
 - There is a question, problem, or statement but no answer choices.
 - You have to write your answer or work out a problem.
 - Read the question carefully and think about what you are asked to do.
 - In English Language Arts (ELA), go back to the passage to look for details and information.
 - You will be scored on accuracy and how well you support your answer with evidence.

- * **Extended constructed-response items**
 - English Language Arts (ELA) and Mathematics only
 - These are similar to the constructed-response items.
 - Sometimes they have more than one part, or they require a longer answer.
 - Check that you have answered all parts of the question.

- * **Extended writing prompt**
 - English Language Arts (ELA) only
 - There is a question, problem, or statement.
 - You may be asked to do more than one thing.
 - In English Language Arts (ELA), you will be asked to read two passages and then write an essay.
 - You will be scored on how well you answer the question and the quality of your writing.
 - Organize your ideas clearly.
 - Use correct grammar, punctuation, and spelling.
 - Support your answer with evidence from the text.

DEPTH OF KNOWLEDGE

Test questions are designed with a Depth of Knowledge (DOK) level in mind. As you go from Level 1 to Level 4, the questions get more and more challenging. They take more thinking and reasoning to answer. You may have experienced these types of questions in your classroom as your teachers find ways to challenge you each day.

A Level 1 item may not require as much thinking as a Level 4 item—but that does not mean it’s easy.

A Level 4 item may have more than one part or ask you to write something.

Here is some information to help you understand just what a DOK level really is.

Level 1 (Recall of Information)

- * Identify, list, or define something.
- * Questions may start with *who*, *what*, *when*, and *where*.
- * Recall facts, terms, or identify information.

Level 2 (Basic Reasoning)

- * Think about things—it is more than just remembering something.
- * Describe or explain something.
- * Answer the questions “how” or “why.”

Level 3 (Complex Reasoning)

- * Go beyond explaining or describing “how and why.”
- * Explain or justify your answers.
- * Give reasons and evidence for your response.
- * Make connections and explain a concept or a “big idea.”

Level 4 (Extended Reasoning)

- * Complex thinking required!
- * Plan, investigate, or apply a deeper understanding.
- * These items will take more time to write.
- * Connect and relate ideas.
- * Show evidence by doing a task, creating a product, or writing a response.

Depth of Knowledge

Level 1—Recall of Information

Level 1 asks you to identify, list, or define. You may be asked to recall *who*, *what*, *when*, and *where*. You may also be asked to recall facts and terms or identify information in documents, quotations, maps, charts, tables, graphs, or illustrations. Items that ask you to “describe” and/or “explain” could be Level 1 or Level 2. A Level 1 item requires that you just recall, recite, or repeat information.

Skills Demonstrated	Question Cues
<ul style="list-style-type: none"> • Make observations • Recall information • Recognize formulas, properties, patterns, processes • Know vocabulary, definitions • Know basic concepts • Perform one-step processes • Translate from one representation to another • Identify relationships 	<ul style="list-style-type: none"> • Tell who, what, when, or where • Find • List • Define • Identify; label; name • Choose; select • Compute; estimate • Express as • Read from data displays • Order

Level 2—Basic Reasoning

Level 2 includes some thinking that goes beyond recalling or repeating a response. A Level 2 “describe” and/or “explain” item would require that you go beyond a description or explanation of information to describe and/or explain a result or “how” or “why.”

Skills Demonstrated	Question Cues
<ul style="list-style-type: none"> • Apply learned information to abstract and real-life situations • Use methods, concepts, and theories in abstract and real-life situations • Perform multi-step processes • Solve problems using required skills or knowledge (requires more than habitual response) • Make a decision about how to proceed • Identify and organize components of a whole • Extend patterns • Identify/describe cause and effect • Recognize unstated assumptions; make inferences • Interpret facts • Compare or contrast simple concepts/ideas 	<ul style="list-style-type: none"> • Apply • Calculate; solve • Complete • Describe • Explain how; demonstrate • Construct data displays • Construct; draw • Analyze • Extend • Connect • Classify • Arrange • Compare; contrast

Level 3—Complex Reasoning

Level 3 requires reasoning, using evidence, and thinking on a higher level than Level 1 and Level 2. You will go beyond explaining or describing “how and why” to justifying the “how and why” through reasons and evidence. Level 3 items often involve making connections across time and place to explain a concept or a “big idea.”

Skills Demonstrated	Question Cues
<ul style="list-style-type: none"> • Solve an open-ended problem with more than one correct answer • Create a pattern • Generalize from given facts • Relate knowledge from several sources • Draw conclusions • Make predictions • Translate knowledge into new contexts • Compare and discriminate between ideas • Assess value of methods, concepts, theories, processes, and formulas • Make choices based on a reasoned argument • Verify the value of evidence, information, numbers, and data 	<ul style="list-style-type: none"> • Plan; prepare • Predict • Create; design • Ask “what if?” questions • Generalize • Justify; explain why; support; convince • Assess • Rank; grade • Test; judge • Recommend • Select • Conclude

Level 4—Extended Reasoning

Level 4 requires the complex reasoning of Level 3 with the addition of planning, investigating, applying deeper understanding, and/or developing that will require a longer period of time. You may be asked to connect and relate ideas and concepts *within* the content area or *among* content areas in order to be at this highest level. The Level 4 items would be a show of evidence—through a task, a product, or an extended response—that the higher level demands have been met.

Skills Demonstrated	Question Cues
<ul style="list-style-type: none"> • Analyze and synthesize information from multiple sources • Examine and explain alternative perspectives across a variety of sources • Describe and illustrate how common themes are found across texts from different cultures • Apply mathematical models to illuminate a problem or situation • Design a mathematical model to inform and solve a practical or abstract situation • Combine and synthesize ideas into new concepts 	<ul style="list-style-type: none"> • Design • Connect • Synthesize • Apply concepts • Critique • Analyze • Create • Prove

ENGLISH LANGUAGE ARTS (ELA)

DESCRIPTION OF TEST FORMAT AND ORGANIZATION

The Grade 7 English Language Arts (ELA) EOG assessment has a total of 60 items.

You will answer a variety of item types on the test. Some of the items are selected-response (multiple-choice), which means you choose the correct answer from four choices. Some items will ask you to write your response using details from the text. There will also be a writing prompt that will ask you to write an essay.

The test will be given in three sections.

- Sections 1 and 2 will be given on Day 1. You may have up to 75 minutes to complete each section.
- Section 3 will be given on Day 2. You will be given a maximum of 90 minutes to complete this section.

CONTENT

The Grade 7 English Language Arts (ELA) EOG assessment will measure the Grade 7 standards that are described at www.georgiastandards.org.

The content of the assessment covers standards that are reported under these domains:

- Reading and Vocabulary
- Writing and Language

There are two kinds of texts—fiction (including stories and poems) and informational text.

There are two kinds of essays—an argumentative essay and an informational/explanatory essay.

Students will also write extended constructed responses that use narrative techniques such as completing a story, writing a new beginning, or adding dialogue. (Item 4 on page 25 gives an example of a prompt that requires a narrative response.)

ITEM TYPES

The English Language Arts (ELA) portion of the Grade 7 EOG assessment consists of selected-response (multiple-choice), constructed-response, extended constructed-response, and extended writing response items.

ENGLISH LANGUAGE ARTS (ELA) DEPTH OF KNOWLEDGE EXAMPLE ITEMS

Example items that represent applicable DOK levels are provided for you on the following pages. The items and explanations of what is expected of you to answer them will help you prepare for the test.

All example and sample items contained in this guide are the property of the Georgia Department of Education.

Example Item 1

DOK Level 1: This is a DOK level 1 item because it requires students to recognize and identify a type of sentence.

English Language Arts (ELA) Grade 7 Content Domain II: Writing and Language

Standard: ELAGSE7L1b. Demonstrate command of the conventions of standard English grammar and usage when writing or speaking. b. Choose among simple, compound, complex, and compound-complex sentences to signal differing relationships among ideas.

Read this sentence.

I went to the spring to get some water, and I saw a deer drinking there.

Which type of sentence is this?

- A. simple
- B. compound
- C. complex
- D. compound complex

Correct Answer: B

Explanation of Correct Answer: The correct answer is choice (B) compound. The sentence has two independent clauses joined by a comma and a coordinating conjunction. Choice (A) is incorrect because there is more than one independent clause. Choices (C) and (D) are incorrect because the sentence does not have a subordinate clause.

In this section, you will read two passages about the ongoing debate about providing food to wild birds. What are the advantages and disadvantages of feeding the birds? You will answer two questions and then write an argumentative essay supporting either side of the debate in which you argue for or against feeding the wild birds.

Before you begin planning and writing, read these two passages:

- 1. Stop Feeding Wild Birds**
- 2. For the Birds**

As you read the passages, think about what details from the passages you might use in your argumentative essay. Read these two passages about the migration of birds and answer Example Items 2 through 4.

Stop Feeding Wild Birds

Many people believe that they can do their part to help wildlife by providing food for wild birds. They believe it helps the birds become healthier and stronger and ensures they have food during times of scarcity. Often, however, this isn't the case. In natural settings, birds feed on a wide variety of foods that nature provides for them and that satisfies all their nutritional requirements. At artificial feeding sites, many birds have been found to suffer from diseases and poor nutrition. The foods many people choose to feed birds, such as bread, crackers, and popcorn, are low in protein.

Natural food locations are scattered everywhere. Birds that have to look for food on their own can easily find it in places where they can eat in relative seclusion. At artificial feeding sites, however, the birds often have to compete. Artificial feeding attracts birds in large numbers and encourages them to linger at the sites, looking for handouts rather than following their natural migration paths south. Many birds are unable to compete because the competition is too high. Furthermore, the number of birds that remain near the feeders often exceeds the natural water supplies in the area. When birds change their migration patterns or stop migrating altogether, many of them may not survive the winter. If people stopped feeding them before the time they normally migrate, the birds would have a better chance of finding natural foods and following their companions to warmer climates.

Wild birds can become dependent on the handouts. When this happens, their behaviors change. Many become aggressive as they struggle to compete for their share. Many lose their wariness of humans and, eventually, their wildness.

In order to keep these creatures wild, people must stop feeding them. They can still visit sites where birds nest and enjoy these birds in their natural habitats, not in artificial ones.

For the Birds

As you learn to enjoy the beauty of birdlife around your home, you may wish to improve the habitat in your yard so that more birds will visit your property. You can attract birds by placing bird feeders, nest boxes, and birdbaths in your backyard and by planting a variety of trees, shrubs, and flowers. These can provide good nesting sites, winter shelter, places to hide from predators, and natural food supplies that are available year-round.

It doesn't matter where you live—in an apartment, a townhouse, or a single-family dwelling in the city, suburbs, or country. Just stand still, and you'll hear them—wild birds. It is hard to imagine life without them.

Bird watching is one of the fastest growing forms of outdoor recreation in the country. Each year millions of people discover for the first time the joys of bird watching. It's easy to understand why. Birds are fun to watch. And you can watch them just about everywhere. The most convenient place to start is right in your own backyard. All it takes to get their attention is food or water, a place to build a nest, and appropriate vegetation.

When you want to attract a particular bird species and keep it returning to your backyard, what you do will be determined by where you live and the time of year. When the ground is covered with snow and ice, it's hard to resist tossing seed out the door. But it's healthier for the birds to get their handouts at a feeding station, rather than off the ground. You can start simply with a piece of scrap wood elevated a few inches above the ground. Add a few holes for drainage, and you've built a platform feeder. It won't be long before the birds find it. If too many birds at your feeder become a problem, you can control their numbers by putting out smaller amounts of seed or by using specialty seeds or restrictive feeders that will attract only certain species. If you fill your feeder only when it's empty, the birds will look for food elsewhere.

Example Item 2

DOK Level 2: This is a DOK level 2 item because the student has to use the context clues in the text to determine the meaning of a vocabulary word.

English Language Arts (ELA) Grade 7 Content Domain: Reading and Vocabulary

Genre: Informational

Standard: ELAGSE7L4a. Determine or clarify the meaning of unknown and multiple-meaning words and phrases based on Grade 7 reading and content, choosing flexibly from a range of strategies. a. Use context (e.g., the overall meaning of a sentence or paragraph; a word’s position or function in a sentence) as a clue to the meaning of a word or phrase.

Which is the BEST definition for the phrase *relative seclusion* as it is used in these sentences from “Stop Feeding Wild Birds”?

Natural food locations are scattered everywhere. Birds that have to look for food on their own can easily find it in places where they can eat in relative seclusion. At artificial feeding sites, however, the birds often have to compete.

- A. quiet
- B. shelter
- C. privacy
- D. isolation

Correct Answer: C

Explanation of Correct Answer: The correct answer is choice (C) privacy. The sentence makes it clear that the birds can eat in privacy, or without being disturbed, because their food sources are “scattered” over an area. Choice (A) is incorrect because the paragraph implies that scattered food sources prevent competition, not the absence of noise. Choice (B) is incorrect because it implies that the birds are somehow safer if the birds do not feed near one another; the sentences do not suggest this. Choice (D) is incorrect because it presumes that the birds have removed themselves entirely from other feeding birds.

Example Item 3

DOK Level 3: This is a DOK level 3 item because students are asked to analyze and explain how the authors use different types of evidence and styles of writing to present their views and support their ideas. There is more than one correct answer, and students must draw conclusions.

English Language Arts (ELA) Grade 7 Content Domain: Reading and Vocabulary

Genre: Informational

Standard: ELAGSE7RI9. Analyze how two or more authors writing about the same topic shape their presentations of key information by emphasizing the different evidence or advancing different interpretations of facts.

Explain the difference in how the authors of “Stop Feeding Wild Birds” and “For the Birds” support their arguments about humans feeding birds.

Use details from both passages to support your answer. Write your answer on the lines provided.

A large rectangular box containing 18 horizontal lines for writing an answer.

Scoring Rubric

Points	Description
2	<p>The exemplar shows a full-credit response. It achieves the following:</p> <ul style="list-style-type: none"> • Gives sufficient evidence of the ability to contrast the evidence and support provided in the texts • Includes specific examples/details that make clear reference to the texts • Adequately contrasts the evidence and support with clearly relevant information based on the texts
1	<p>The exemplar shows a 1-point response. It achieves the following:</p> <ul style="list-style-type: none"> • Gives limited evidence of the ability to contrast the evidence and support provided in the texts • Includes vague/limited examples/details that make reference to the texts • Contrasts the evidence and support with vague/limited information based on the texts
0	<p>The exemplar shows a response that would earn no credit. It achieves the following:</p> <ul style="list-style-type: none"> • Gives no evidence of the ability to contrast the evidence and support provided in the texts

Exemplar Response

Points Awarded	Sample Response
2	<p>The authors use different styles of writing to present their views about feeding wild birds, and they use different types of evidence to support their views. The author of “Stop Feeding Wild Birds” uses a straightforward, explanatory tone. The article begins by addressing the fact that many people believe feeding birds helps them survive. Then it provides a series of facts that explain why this belief is incorrect. This article outlines the problems, giving specific examples of how feeding wild birds can harm them. For example, the article talks about how feeding wild birds makes them dependent on humans because the birds are no longer able to find food for themselves, and they can fall out of their natural migration patterns.</p> <p>The author of “For the Birds” appeals to people’s emotions about caring for wildlife. The article begins by stressing the enjoyment people can get from observing and caring for birds and then provides suggestions for how to set up a feeding station. The author claims that properly managing a feeding station can eliminate some of the problems that can occur as a result of feeding wild birds. The article focuses on the enjoyment people get from wild birds and clearly promotes the practice for the sake of the birds as well as the people.</p>
1	<p>The authors use different styles of writing to present their views about feeding wild birds, and they use different types of evidence to support their views. The author of “Stop Feeding Wild Birds” uses a straightforward, explanatory style to outline the problems with feeding the birds. It then includes specific instances in which feeding wild birds has harmed them. The author of “For the Birds” stresses the enjoyment people can get from observing and caring for birds, and then provides suggestions for how to set up a feeding station. The article clearly encourages the practice of feeding.</p>
0	<p>The authors use different evidence to present their points of view about feeding wild birds and whether it is good for the birds or whether it actually harms them.</p>

Example Item 4

DOK Level 4: This is a DOK level 4 item because it goes beyond explaining to analyzing and synthesizing information from different sources. The student must combine ideas from the two passages and write an essay in response to an extended writing-prompt.

English Language Arts (ELA) Grade 7 Content Domain: Writing and Language

Genre: Informational

Standard: ELAGSE7W1. Write arguments to support claims with clear reasons and relevant evidence.

Now that you have read “Stop Feeding Wild Birds” and “For the Birds,” create a plan for and write your argumentative essay.

WRITING TASK

Review the claims on both sides. Choose a side, and then write an argumentative essay supporting either side of the debate. You will argue for or against feeding wild birds.

Be sure to use information from BOTH passages to support the side you have chosen. **Write your answer on the lines provided.**

Before you write, be sure to:

- Think about ideas, facts, definitions, details, and other information and examples you want to use.
- Think about how you will introduce your topic and what the main topic will be for each paragraph.
- Develop your ideas clearly and use your own words, except when quoting directly from the passages.
- Be sure to identify the passages by title or number when using details or facts directly from the passages.

Now write your argumentative essay. Be sure to:

- Introduce your claim.
- Support your claim with logical reasoning and relevant evidence from the passages.
- Acknowledge alternate or opposing claims.
- Organize the reasons and evidence logically.
- Use words, phrases, and clauses to connect your ideas and to clarify the relationships among claims, counterclaims, reasons, and evidence.
- Establish and maintain a formal style.
- Provide a concluding statement or section that follows from and supports the argument presented.
- Check your work for correct usage, grammar, spelling, capitalization, and punctuation.

The following are examples of a seven-point response. See the seven-point, two-trait rubric for a text-based argumentative response on pages 67 and 68 to see why these examples would earn the maximum number of points.

Examples of a Seven-Point Response:

Though many people believe that feeding wild birds helps them survive in times when food is scarce, it actually causes the birds more harm than good. Birds are born to be wild, and they know by instinct how to find food on their own.

The author of “Stop Feeding Wild Birds” claims that when people feed these wild birds, the birds become dependent on humans for survival. The birds lose their ability to survive on their own. The author explains that birds that eat food provided by humans are more likely to be undernourished and suffer from diseases. Nature provides birds with a variety of foods that satisfy all their nutritional requirements. People tend to give them foods that are low in protein, such as popcorn and bread.

Feeding wild birds also changes their migration patterns. The author of “Stop Feeding Wild Birds” claims that some birds remain at the feeders and stop migrating altogether. As a result, they suffer because when the cold weather arrives, they are not able to survive through the winter. If they fly south to a warmer climate, they find a variety of natural foods along their migration paths.

The author of “For the Birds” claims that with enough knowledge about bird behaviors, feeding them can help ensure they have an adequate food supply. The author stresses the enjoyment people can get from observing and caring for birds in their own yards and acknowledges the fact that it’s hard to imagine life without wild birds. Yet the author correctly implies that the best way to protect birds is keep them wild.

OR

There’s no question that many people enjoy watching wild birds. Many people also enjoy feeding them, and their intentions are good. The problem is that though these people think they are helping the birds, they may actually be harming them—not because they shouldn’t be feeding them, but because they have not taken the time to learn about wild birds and how to feed them correctly.

The author of “For the Birds” explains that during times of cold weather, it’s tempting to simply throw food for the birds on the ground. The author points out that it’s healthier to create a feeding station, however. The author also points out that a feeding station allows people to control the amount of food they make available for the birds. This prevents the problem of having too many birds at the feeder, which the author of “Stop Feeding Wild Birds” cites as a reason to stop feeding them.

If people stop feeding the birds, they miss an opportunity to help protect them. For example, as the author of “For the Birds” explains, providing feeding stations for birds helps them hide from predators and ensures they have something to eat. People who genuinely care about wild birds will take the time to learn their habits. As the author of “For the Birds” points out, they can use “specialty foods” to attract certain species. They can learn about the birds’ nutritional requirements to ensure that the food they feed them is healthy. They don’t have to feed them a diet that consists mainly of popcorn and bread. Once people learn what wild birds need, creating habitats and feeding the birds can help their survival.

ENGLISH LANGUAGE ARTS (ELA) CONTENT DESCRIPTION AND ADDITIONAL SAMPLE ITEMS

In this section, you will find information about what to study in order to prepare for the Grade 7 English Language Arts EOG assessment. This includes key terms and important vocabulary words. This section also contains practice questions, with an explanation of the correct answers, and activities that you can do on your own or with your classmates or family to prepare for the test.

All example and sample items contained in this guide are the property of the Georgia Department of Education.

Unit 1: Reading Literary Text

READING PASSAGES: LITERARY TEXT

CONTENT DESCRIPTION

The literary passages in the English Language Arts (ELA) test are used to identify main ideas and details, cite evidence, make inferences, determine themes, and understand vocabulary.

Key Ideas and Details

- Ideas and details tell you what the story or poem is about.
- Use these ideas and details when writing or speaking about the story or poem.
- Look for central ideas or themes as you read. Ask yourself—what is this about?
- Think about the characters, setting, and events in the story.
- Summarize the important details and ideas after you read.

Structure of the Text

- Make sure you understand the words and phrases as you read.
- Think about how specific words can help you understand the meaning or tone.
- Look at the structure of stories. Pay attention to how the parts of the text (e.g., a section, chapter, scene, or stanza) work with each other and the story or poem as a whole.
- Think about the point of view or purpose of a text.

Understanding What You Read

- Think about the story and visualize, or make a mental picture, as you read.
- Think about the message or what the writer is trying to say.
- Think and use various reading strategies (e.g., context clues, paraphrasing, referring back to the passage, etc.), even when presented with a difficult text.

KEY TERMS

Inference: To infer means to come to a reasonable conclusion based on evidence found in the text. By contrast, an **explicit** idea or message is fully stated or revealed by the writer. The author tells the readers exactly what they need to know. (RL1)

Theme: The theme of a literary text is its lesson or message. For example, a story could be about two friends who like to do things together, and the theme might be the importance of friendship. (RL2)

Plot: The series of events that form a story in a specific order. (RL3)

Resolution: In most stories there is a conflict or problem. The resolution is the solution to the problem or the end of the main dramatic conflict. (RL3)

Figurative language: To understand figurative language, you need to distinguish between literal and figurative meanings of words and phrases. Literal refers to the actual meaning of a word or phrase. For example, if someone tells you to open the door, you can open a physical door. If someone tells you to “open the door to your heart,” you are being encouraged to open up your feelings and emotions.

Examples of figurative language are similes and metaphors. **Similes** make comparisons using a linking word such as *like*, *as*, or *than* (her eyes shone like the stars). A **metaphor** makes a comparison without a linking word; instead of being *like* another, one thing *is* another (her eyes were shining stars). (RL4)

Alliteration: The use of the same sound to start several words in a row. For example, *The beautiful butterfly blew by the bay*. Literary devices such as alliteration can have a big impact on poems, stories, and dramas. (RL4)

Point of view: The perspective from which a story is told. The point of view depends upon who the narrator is and how much he or she knows. The point of view could be first person (*I* went to the store), second person (*You* went to the store), or third person (*He* went to the store). (RL6)

Compare vs. contrast: Though similar, comparing is analyzing two things such as characters or stories in relation to each other, while contrasting is specifically analyzing the *differences* between two things such as two different characters or stories. (RL7/RL9)

Genre: A genre is a category of passages, such as fiction and nonfiction. Each genre has a particular style, form, and content. (RL9)

Important Tips

- ✍ Use details to support ideas and answer about *what* you know and *how* you know it.
- ✍ Try to answer the question before you read the answer choices.
- ✍ Try to read the questions about a literary text before you read the entire text.
- ✍ Re-read a literary text as you answer the questions to gain a better understanding.

Sample Items 1–4

Use this passage to answer questions 1 through 4.

Around the World in Eighty Days **by Jules Verne**

Mr. Phileas Fogg lived, in 1872, at No. 7, Saville Row, Burlington Gardens, the house in which Sheridan died in 1814. He was one of the most noticeable members of the Reform Club, though he seemed always to avoid attracting attention; an enigmatical¹ personage, about whom little was known, except that he was a polished man of the world. People said that he resembled Byron—at least that his head was Byronic; but he was a bearded, tranquil² Byron, who might live on a thousand years without growing old. . . .

Was Phileas Fogg rich? Undoubtedly. But those who knew him best could not imagine how he had made his fortune, and Mr. Fogg was the last person to whom to apply for the information. He was not lavish, nor, on the contrary, avaricious;³ for, whenever he knew that money was needed for a noble, useful, or benevolent⁴ purpose, he supplied it quietly and sometimes anonymously. He was, in short, the least communicative of men. He talked very little, and seemed all the more mysterious for his taciturn⁵ manner. His daily habits were quite open to observation; but whatever he did was so exactly the same thing that he had always done before, that the wits of the curious were fairly puzzled.

Had he travelled? It was likely, for no one seemed to know the world more familiarly; there was no spot so secluded that he did not appear to have an intimate acquaintance with it. He often corrected, with a few clear words, the thousand conjectures⁶ advanced by members of the club as to lost and unheard-of travelers, pointing out the true probabilities, and seeming as if gifted with a sort of second sight, so often did events justify his predictions. He must have travelled everywhere, at least in the spirit. . . .

Phileas Fogg was not known to have either wife or children, which may happen to the most honest people; either relatives or near friends, which is certainly more unusual. He lived alone in his house in Saville Row, whither none penetrated. A single domestic sufficed to serve him. He breakfasted and dined at the club, at hours mathematically fixed, in the same room, at the same table, never taking his meals with other members, much less bringing a guest with him; and went home at exactly midnight, only to retire at once to bed. . . . When he chose to take a walk it was with a regular step in the entrance hall with its mosaic flooring, or in the circular gallery. . . . When he breakfasted or dined all the resources of the club—its kitchens and pantries, its buttery and dairy—aided to crowd his table . . . he was served by the gravest waiters, in dress coats, and shoes with swan-skin soles . . . and on the finest linen; . . . while his beverages were refreshingly cooled with ice, brought at great cost from the American lakes. . . .

¹**enigmatical:** mysterious

²**tranquil:** calm

³**avaricious:** greedy

⁴**benevolent:** kind

⁵**taciturn:** silent

⁶**conjectures:** guesses

Item 1

Which of these **BEST** describes the theme of the passage?

- A. A worldly but private man avoids dining out in public.
- B. A worldly but private man is difficult to get to know.
- C. A worldly but private man boasts of his wide travels.
- D. A worldly but private man is hiding a terrible secret.

Item 2

What is the **MOST LIKELY** reason that Phileas Fogg spends so much time alone?

- A. He is afraid of being asked for money.
- B. He has little respect for his acquaintances.
- C. He feels very insecure about his appearance.
- D. He prefers his own company to that of others.

Item 3

What does *domestic* mean as it is used in this sentence?

A single domestic sufficed to serve him.

- A. local
- B. native
- C. servant
- D. outsider

Item 4

The story was written using the third-person point of view. How would the excerpt be different if Phileas Fogg were narrating? Rewrite the beginning of the story from Phileas Fogg’s perspective.

Write your answer on the lines provided.

A large rectangular box containing 25 horizontal lines for writing the answer.

Unit 2: Reading Informational Text

READING PASSAGES: INFORMATIONAL TEXT

CONTENT DESCRIPTION

The informational and explanatory passages in the English Language Arts test can be used to determine central ideas, write an objective summary, analyze ideas, and provide supporting text evidence.

Key Ideas and Details

- Read closely to know exactly what the text says.
- Look for details that tell what the text is about.
- Use those details when writing or speaking about the text.
- Look for the central ideas in the text.
- Summarize the important details and ideas.
- Think about how ideas develop and work together in the text.

Structure

- Make sure you understand the words in the text.
- Use a dictionary, thesaurus, or glossary to help you with words that are new.
- Look at how the parts of the text work with each other.
- Think about the author's point of view or purpose in the text.

Understanding the Text

- Think about the text as if it were presented as a movie or a television show.
- Think about the text and its message.
- Look for details or evidence in the text.

KEY TERMS

Summary: A summary is an overview of a text that captures the main points but does not give all of the details and does not include opinions. (RI2)

Interactions: How ideas influence individuals or events or how individuals influence ideas or events. As one analyzes the interactions in a text, they give insight into the meaning. (RI3)

Connotative meaning: A meaning beyond the explicit meaning of a word. For example, the word *childlike* connotes innocence as well. Connotations are meanings inferred from certain words. (RI4)

Organization: The way in which a piece of writing is structured. Each sentence, paragraph, or chapter fits into the overall structure of a text and contributes to the development of ideas. Organizational structures can include chronological order, sequential order, cause and effect, problem and solution, compare and contrast, order of importance, spatial order, etc. (RI5)

Author's purpose: The author's intention for his or her piece. All passages have a purpose, whether it is to persuade, inform, explain, or entertain. (RI6)

Author's point of view: The opinion of the author. Your opinion may differ from the opinion of the author writing a passage. (RI6)

Evidence: Something that proves or demonstrates the truth of something else. Informational texts may contain evidence to prove that the information they are providing is correct. (RI8)

Fact and opinion: A **fact** is a statement that can be proven. An **opinion** is a statement that cannot be proven because it states a writer's belief or judgment about something. Deciding whether or not a statement is a fact or an opinion often comes down to a single question: "Can you prove it?" If you can prove a statement, then it is a fact. If not, it's an opinion. (RI2)

Chronological order: The order in which a series of events happened. A text that is arranged in order of time from the beginning to the end is in chronological order. (RI5)

Cause and effect: This is a relationship where one thing causes another thing to happen. A passage may also be organized by stating the **problem and solution** as well. (RI3)

Important Tips

- ✍ Try to read the questions about an informational text before you read the text so that you know what to look out for.
- ✍ Use evidence from a passage to help explain what is being said.
- ✍ Use facts and details to support ideas and answer *what* you know and *how* you know it.

Sample Items 5–8

Read the following passage and answer questions 5 through 8.

Putting Americans Back to Work

The stock market crash in October 1929 caused a worldwide economic depression that lasted a decade and affected nearly every nation in the world. The United States was no exception. At the height of the downturn, nearly 20% of Americans were out of work—that's 1 in 5 Americans. To combat unemployment, the government led by President Franklin D. Roosevelt began in 1935 a program called the Works Project Administration (WPA). It oversaw the construction of public roads, dams, bridges, and buildings. The jobs created by these projects put millions of Americans back to work. But some people had talents that were not suited to building things. To help them, the government expanded the WPA to include federal works projects dedicated to preserving American culture and the arts. The result was the Federal Arts Project, the Federal Theater Project, the Federal Music Project, and the Federal Writers' Project. Each of these programs put talented artists, musicians, actors, and writers to work again.

Under the Federal Arts Project, American artists received unexpectedly large canvases on which to paint their works—the walls of public buildings, including the lobbies of courthouses, post offices, bridges, dams, and customs houses. The program was the brainchild of George Biddle, an artist and friend of President Roosevelt. While in Mexico, he had seen the spectacularly colorful and powerful murals by artists such as Diego Rivera. These huge wall paintings depicted the people of Mexico and celebrated their cultures and traditions. The paintings' purpose was to inspire people to feel pride and also provide some beauty in their daily lives. Biddle thought that American artists could do something similar in the United States. Beginning in 1933, artists began submitting sketches to government-sponsored contests. Winning drawings were then transformed by teams of artists into glorious murals on the walls of federal buildings in their communities. The artwork reflected the local people and their work and values. Many depicted farmers. Others depicted industrial or urban scenes. Many of these paintings still exist today.

The Federal Theater Project helped put nearly 10,000 writers, actors, and theater technicians to work between 1935 and 1939. Like the Federal Arts Project, this program was intended to help keep actors and playwrights employed during tough economic times. The director of the Federal Theater Project was Hallie Flanagan, a teacher and a playwright. Under her guidance, writers and actors staged nearly 1,000 original plays that were performed in 40 states. Most were presented at no cost to the public. The performances included new interpretations of classic dramas as well as original productions of dramas, comedies, and musicals. There were also shows aimed for children. Many struggling playwrights got their start by working for the Federal Theater Project. After the end of the Great Depression, several went on to achieve fame on Broadway and Hollywood.

The Federal Music Project only lasted four years, but it had a tremendous impact on American music. Like the Federal Arts Project and the Federal Theater Project, it was created to provide employment for out-of-work musicians, including composers, singers, teachers, and instrumentalists. Many were formed into orchestras and bands that performed around the country. Others conducted classes to teach Americans how to sing.

Perhaps the most important result of the federal projects was the fieldwork done by writers assigned to the Folklore Section of the Federal Writers' Project. These writers were dispatched across the United States with heavy recording equipment to document the stories, anecdotes, verse, and songs of ordinary Americans. The result was a goldmine of uniquely American material, including oral histories describing life during the days of slavery and traditional folk songs and lore from isolated communities. Without the Federal Writers' Project, precious bits of American culture and lore might have been lost. Today, anyone can explore the fieldworkers' findings by visiting the American Folklife Center at the Library of Congress, where they will be preserved forever.

Although the federal works projects only lasted for a short time—about five years—they had a tremendous impact on the nation, and not only in terms of its economy. The production of artwork, songs, and plays and the preservation of unique lore allowed Americans to remember and appreciate their diverse culture. Most Americans may have felt down and out during the Great Depression, but thanks in part to the federal works projects, they discovered they had then and would always have tremendous creative wealth.

Item 5

Which sentence would be the MOST important to include in a summary of the passage?

- A. Many jobless Americans reconnected with their cultural roots during the 1930s.
- B. The art on most U.S. post offices today was produced during the Great Depression.
- C. President Franklin D. Roosevelt led the United States out of an economic downturn.
- D. The federal government created jobs for unemployed artists, musicians, and writers.

Item 6

What was the MAIN reason President Roosevelt created the federal works projects?

- A. to provide artists, musicians, and writers with employment
- B. to lower the unemployment rate for government workers
- C. to show the importance of cultural traditions
- D. to promote national pride through the arts

Item 7

Describe the structure the author uses to organize the text and how it contributes to the development of ideas in the passage.

Support your answer with details from the text. Write your answer on the lines provided.

Item 8

What effect did the federal works programs created by President Roosevelt have on unemployed Americans during the Great Depression?

Use details from the passage in your response. Write your answer on the lines provided.

A large rectangular box containing 20 horizontal lines for writing an answer.

Unit 3: Writing Informational/Explanatory Texts

CONTENT DESCRIPTION

The informational/explanatory passages in the English Language Arts test help develop your writing. Informational writing states ideas, summarizes research, and uses information from more than one source.

Text Types and Purposes

- Write informational/explanatory texts to state ideas and information clearly and accurately.
- Use the best details, organize them, and explain them when necessary.

Production and Distribution of Writing

- Produce writing with organization and style that fits the task, purpose, and audience.
- Develop and strengthen writing by planning, revising, editing, rewriting, or trying a new approach.
- Use technology, including the Internet, to produce and share writing.

Audience, Purpose, and Voice

- As you write, remember who your audience will be.
- Make sure your writing is appropriate. Watch your tone, style, and voice.
- Remember, you are writing for a purpose—think about *what* you are writing and *why*.

Range of Writing

- Write routinely over extended time frames (time for research, reflection, and revision) and shorter time frames (a single sitting or a day or two) for a range of tasks, purposes, and audiences.

Scoring Rubrics

- Scoring rubrics can be found beginning on page 62. You may find it helpful to read and discuss these with a parent or another adult.
- The rubrics show you what is needed to produce a strong piece of writing.
- Rubrics are important to understand. They tell you what to add to your writing.
- Writing on the EOG assessment will be scored using these rubrics.

KEY TERMS

Informational/explanatory texts are forms of writing that inform the reader or explain something. (W2d)

Introduction: The beginning of a piece of writing. The introduction should let readers know what they will be reading about and set up the main idea of the writing. (W2a)

Organization: The way in which a piece of writing is structured. Similar ideas and illustrations should be grouped together, and the order of the information should make sense. (W2a/W4)

Transition: A word, phrase, or clause that links one idea to the next. Writing should not jump from one idea to the next without transitions that guide the reader to the next idea. Examples include words such as “another,” “for example,” “also,” and “because.” (W2c)

Conclusion: The end of a piece of writing is the conclusion. The conclusion should sum up the main idea of the writing and provide an overall message for the reader. (W2f)

Formatting: The way in which a piece of writing is organized. For example, a writer can use headings and subheadings to organize the writing and present the information in a clear way. (W2a)

Multimedia: A variety of mediums. Writing does not only include pen to paper or a typed essay. Other ways of enhancing writing can include mediums such as art, presentations, photographs, charts, videos, and more. (W2a)

Writing process: Most informational or technical pieces require hard work and revision before they can be considered ready. Even professional writers may struggle with their words. Drafting, revising, editing, and proofreading your writing are all essential parts of an effective writing process. The steps in the writing process are prewriting, drafting, revising and editing, proofreading, and publishing. (W5)

Important Tips

- ✍ Begin by organizing your ideas in different sections. You can use a graphic organizer such as a chart or Venn diagram, or you can create an outline of your writing. Then it will be easier to fill in the supporting details.
- ✍ Be sure to develop your writing with details such as facts, definitions, quotations, or other information that supports your topic.
- ✍ Organize your writing by using chronological order, cause and effect, compare and contrast, or asking and answering questions.
- ✍ Make sure your writing has a concluding statement that supports your central idea.
- ✍ Strengthen your writing by planning, revising, editing, rewriting, or trying a new approach.

Sample Items 9–12

[**NOTE:** The structure of the practice items for Unit 3 and Unit 4 is as it appears on the Georgia Milestones End-of-Grade assessment: 1) multiple-choice questions (three on the actual test); 2) a constructed-response item; and 3) an extended writing prompt. Additionally, the instructions for the extended writing prompt are in a format that is similar to the one on the End-of-Grade assessment. There is no extended writing prompt in this unit.]

In this section, you will read a passage and answer questions 9 through 12. You will read about one person’s perspective on living and studying abroad. What are the benefits and difficulties of living in a foreign country? You will answer four questions about the passage.

Read this passage and answer questions 9 through 12.

From Culture Shock to Cultural Exchange

The whole point of being an exchange student is to go to a new place, meet new people, and discover how full of variety and surprises the world is. Most exchange students begin the process by dreaming about the places around the globe they would most like to explore. For me, that place was the United States. Even though I live in one of the busiest, most crowded, and most exciting cities in the world, Mumbai, India, I desperately wanted to go to America to study for a year. With my parents’ help and encouragement, I completed the arduous application process, which involved several interviews and the writing of an essay, and I was accepted. I was to spend 10 months with a family in a small town I had never heard of, called Gettysburg, Pennsylvania. Looking back now, I realize I had no idea of what was in store for me.

Once I was accepted, there was a series of classes I attended to help me prepare for my year abroad. There was a lot of paperwork involved in getting my passport and securing a student visa to enter the United States. I also had to make sure I had health insurance in case I got sick. There were also classes about how to avoid getting culture shock. Everyone thinks they know what America is like from watching movies and television shows, but as I found out, the country and its culture are very different from what I was used to. For example, Mumbai is the capital of the state of Maharashtra. It is about 240 square miles and has a population of nearly 12 million people. It’s the financial and business center of all of India, much like New York City is in the United States. If my host family had lived in NYC, I might have had an easier time adjusting. But Gettysburg is a sleepy little town of about 7,500 people. It is surrounded by apple farms and is best known for being the site of an important battle during the American Civil War. Thousands of people visit Gettysburg every year to view the battlefield, which covers about 9 square miles (23 square km) and is adorned with more than 1,600 monuments commemorating the three-day battle that took place there on July 1, 2, and 3, 1863. Many of the statues are beautiful, depicting confident generals atop their enormous horses. The first time I saw one of those statues against the backdrop of cloudless autumn sky, I felt my breath quicken. It was that amazing.

My reaction is one of the things my exchange student coordinator warned me about. He said I would likely suffer from culture shock after I arrived in the U.S., and he was right. It's a process with several stages. First, you feel excited because everything around you is new. You feel like the luckiest person in the world to be in this new place. Everyone acts friendly and kind and—best of all—interested in you, because you are from a place they have never heard of. My coordinator said this is called the “honeymoon period” because it is like when a couple first gets married. Everything seems perfect, and you expect that feeling to last forever. It doesn't, of course.

Next, you enter the “frustration stage.” That's the stage when cultural differences seem less charming and more annoying. In my case, I began to weary of the food. In India, the food we eat is often peppery hot and fragrant with spices. It helps us feel cool while living in a hot and humid climate. In the U.S. much of the food struck me as bland. Sometimes I would look down at my plate and see only food that was white or yellow—plain corn, mashed potatoes, white bread, and a slice of meat. The weather was a factor, too. South central Pennsylvania has wet, cold winters that last far longer than in Mumbai. Even though I had brought a warm coat and waterproof boots, I felt constantly cold. I was so glad when spring arrived.

The last phase of cultural shock is acceptance or adoption. You start to think critically—meaning you begin to thoughtfully evaluate and compare the two cultures. You begin to see the values that you admire and the practices that you might adopt when you return home. You begin to realize that the world is truly a big place, and there is room in the world for many, many different ways of being and thinking. That's a great thing for an exchange student to take home, but the very best thing is the memories you form.

Item 9

To maintain the formal style, which sentence would be MOST appropriate to add to the essay?

- A. I totally believe you should become an exchange student because it is an awesome experience.
- B. I recommend that potential exchange students read about others' experiences before applying.
- C. I think that being an exchange student is a super experience that everyone should try.
- D. I guess the world wouldn't be so topsy-turvy if there were more exchange students.

Item 10

Which sentence should be added to the end of the final paragraph to provide the BEST conclusion?

- A. And unlike Mumbai, Gettysburg is mostly flat and far from the ocean.
- B. The first thing to do is think carefully about where you wish to study.
- C. So, don't be concerned about culture shock because it doesn't last.
- D. Your visit might last a year, but your memories will last a lifetime.

Item 11

How does the author support the idea that culture shock is an unavoidable part of the experience of living and studying abroad?

Use details from the passage to support your answer. Write your answer on the lines provided.

<hr/> <hr/> <hr/> <hr/> <hr/> <hr/> <hr/> <hr/> <hr/> <hr/> <hr/> <hr/> <hr/> <hr/> <hr/> <hr/> <hr/> <hr/> <hr/> <hr/> <hr/> <hr/> <hr/> <hr/> <hr/> <hr/> <hr/> <hr/> <hr/>

Item 12

How did coming from Mumbai contribute to the author’s experience in the United States?

Use details and information from the passage to support your answer. Write your answer on the lines provided.

A large rectangular box containing 25 horizontal lines for writing an answer.

Unit 4: Writing Argumentative Texts

CONTENT DESCRIPTION

The argumentative passages in the English Language Arts test help you develop arguments and claims and support a point of view on a topic. In your writing, use evidence, examples, quotations, and reasons to develop and support your claims and arguments.

Purpose

- An argumentative piece takes a stand or agrees or disagrees with a point of view.
- Some common words are “agree” or “disagree” or “for” or “against.”
- When you state your argument, you need to support it with claims, reasons, examples, and evidence.

Editing Your Writing

- Check your writing for good organization.
- Make sure your writing fits the task, purpose, and audience.
- Strengthen your writing by planning, revising, editing, rewriting, or trying a new approach.
- Use technology, including the Internet, to do research.

Scoring Rubrics

- Scoring rubrics can be found beginning on page 62. You may find it helpful to read and discuss these with a parent or another adult.
- The rubrics show you what is needed to produce a strong piece of writing.
- Rubrics are important to understand. They tell you what to add to your writing.
- Writing on the EOG assesment will be scored using these rubrics.

KEY TERMS

Claims: Ideas and opinions set forth by the author. For example, a writer could make the claim that the school cafeteria food is too expensive. In a well-developed argumentative essay, the writer should also recognize alternate or opposing claims. (W1a)

Evidence: The reasons given to support a writer's claims. For example, a writer could include information on the price of school lunch, or the number of students who don't want to buy, as reasons to support the claim that the school cafeteria is too expensive. (W1b)

Relationships: The ways in which ideas are connected. Writing should use words, phrases, and clauses to clarify the relationships among claim(s) and reasons. (W1c)

Purpose: The writer's intention for his or her piece. All writing has a purpose, whether it is to persuade, inform, explain, or entertain. (W4)

Audience: The people who will be reading the piece of writing. Writers should keep their audience in mind and adjust their ideas and vocabulary so that they can be best understood. (W4)

Organization: In writing, the organization helps explain ideas and information more clearly. Writers use transitions to organize information. Also, an entire piece of writing has an organizational structure to it. Writers structure their texts to match their purpose and audience. For example, if you were writing an argumentative text in which you wanted to show the negative effects of something, you might choose cause and effect as an organizational structure. (W1a, W4)

Revision: The process of editing and rewriting a piece of writing. All good writing requires a lot of revision in order to catch mistakes and clarify ideas. (W5)

Important Tips

- ✍ Make sure that the arguments you make in your writing have clear reasons and relevant evidence. The evidence must strongly support your claims.
- ✍ Organize your writing by using chronological order, cause and effect, compare and contrast, or asking and answering questions.
- ✍ Make sure your writing has a concluding statement that supports the information or explanation presented.
- ✍ Always read over your writing several times to check your work and catch errors.

Sample Items 13–16

[**NOTE:** The structure of the practice items for Unit 4 is as it appears on the Georgia Milestones End-of-Grade assessment: 1) multiple-choice questions (three on the actual test); 2) a constructed-response item; and 3) an extended writing prompt. Additionally, the instructions for the extended writing prompt are in a format that is similar to the one on the End-of-Grade assessment.]

In this section, you will read two passages and answer questions 13 through 16.

WRITING TASK

There is a conflict between animal activists concerned with marine life and other users of the planet’s oceans. What are the dangers of underwater noise on certain species like whales?

Review the claims on both sides. Choose a side, and then write an argumentative essay supporting either side of the debate. You will argue that underwater noise affects certain species like whales OR that underwater noise has no affect on marine life.

Be sure to use information from BOTH passages to support the side you have chosen. **Write your answer on the lines provided.**

Before you begin planning and writing, you will read two passages and answer three questions about what you have read. As you read the passages, think about what details from the passages you might use in your argumentative essay. These are the titles of the texts you will read:

1. **What to Do about Underwater Noise**
2. **What Underwater Noise?**

What to Do about Underwater Noise

Anyone who lives in a busy city knows that the world is a noisy place. We humans rely on many machines—planes, cars, trains, construction and farming machinery, and machines in factories—to make modern life happen. As it turns out, we make a racket on land and in the ocean. Our boats, oil drilling equipment, and military sonar activities generate all kinds of noise. Some scientists have become concerned that underwater noise is negatively affecting sea life, particularly whales. In recent years, studies of the impact of underwater noise have been completed, and the results are mixed. Neither side—not the environmentalists who want to protect marine life, nor the Navy, which conducts sonar tests for our national defense—is convinced of the right thing to do.

Some environmentalists are concerned that underwater noise has a negative impact on certain species, particularly beaked whales. Whales communicate with each other by sending out sound waves. Scientists suspect that the increase in underwater noise has interfered with the whales' ability to "hear" one another. They also are concerned that high levels of underwater noise upset the whales. Like humans, whales might also enjoy some peace and quiet. But where can they go? To find out how noise affects whales, scientists attached digital recording devices to beaked whales, pilot whales, and melon-headed whales during a two-year period. These devices measured the sounds the whales made and also tracked their movements. This allowed scientists to determine how the whales reacted when they were in noisy environments. The data suggested that beaked whales were especially sensitive to even low levels of underwater noise. It interrupted their communications and caused them to change their diving and feeding patterns. The results suggested clearly that we should change our attitude toward underwater noise if we want our whale populations to survive.

Should we reduce our underwater activities? Or should we keep doing what we've been doing and hope for the best? We should cut back on underwater noise so that the animals of the sea can thrive. The obvious answer is to err on the side of caution and limit underwater noise.

What Underwater Noise?

Many studies have been conducted to determine whether underwater noise negatively affects sea life. One study concluded that sonar activity and other noises caused beaked whales to change their behaviors. Another study showed there was no such effect.

The United States Navy is also concerned about the issue of underwater noise. The Navy uses sonar, a system of using sound waves to detect objects underwater, as a tool to gather information about our oceans and protect the nation. If that tool were causing harm to the creatures of the sea, then the Navy would want to know it.

The issue became critical after an incident in 2000 in which 17 whales became stranded in the Bahamas. It was thought at the time that the use of Navy sonar nearby was the cause. The Navy collaborated with well-known marine scientific organizations to conduct a study. The researchers attached recording tags to different whales in order to track their activity. Unlike previous studies, researchers also generated specific sounds—sonar pings and the calls of other sea creatures. Then they measured the whales' reactions. At first, some of the beaked whales responded cautiously to the noises, but they did not change their overall behavior. Nor did the other types of whales in the study react fearfully. The Navy concluded that even high levels of sonar and other underwater noise did not affect underwater creatures. As a result, the Navy has argued that it should be allowed to continue its sonar activities in the world's oceans.

While everyone will probably sleep better if there is less noise in the world, the soundness of the U.S. Navy study is also comforting. Underwater noise has no negative impact on marine life.

Item 13

Which sentence should be added to the final paragraph of “What to Do about Underwater Noise” to show that the writer acknowledges an opposing opinion?

- A. To cause the suffering of numerous whales and other sea creatures would be a crime.
- B. To let things remain as they are might be the best course of action given the evidence.
- C. To continue studying the effects of underwater noise is just a waste of time and money.
- D. To ignore the studies that show underwater noise does have an impact is perhaps selfish.

Item 14

Which sentence BEST supports the Navy’s claim in “What Underwater Noise?” about the impact of sonar on certain whales?

- A. Some whales initially reacted negatively to nearby sonar activity.
- B. No whales changed their overall behaviors in response to sonar activity.
- C. Beaked whales changed their feeding patterns in response to sonar activity.
- D. All whales use sound waves to communicate with one another over distances.

Item 15

Read this sentence from the passage “What Underwater Noise?”

One study concluded that sonar activity and other noises caused beaked whales to change their behaviors.

Is this sentence from “What Underwater Noise?” relevant to the author’s main argument?

Use details from the passage to support your response. Write your answer on the lines provided.

Item 16

Now that you have read “What to do Do about Underwater Noise” and “What Underwater Noise?” and answered some questions about what you have read, create a plan for and write your argumentative essay.

WRITING TASK

There is a conflict between animal activists concerned with marine life and other users of the planet’s oceans. What are the dangers of underwater noise on certain species like whales?

Review the claims on both sides. Choose a side, and then write an argumentative essay supporting either side of the debate. You will argue that underwater noise affects certain species like whales OR that underwater noise has no affect on marine life.

Be sure to use information from BOTH passages to support the side you have chosen. **Write your answer on the lines provided.**

Before you write, be sure to:

- Think about ideas, facts, definitions, details, and other information and examples you want to use.
- Think about how you will introduce your topic and what the main topic will be for each paragraph.
- Develop your ideas clearly and use your own words, except when quoting directly from the passages.
- Be sure to identify the passages by title or number when using details or facts directly from the passages.

Now write your argumentative essay. Be sure to:

- Introduce your claim.
- Support your claim with logical reasoning and relevant evidence from the passages.
- Acknowledge alternate or opposing claims.
- Organize the reasons and evidence logically.
- Use words, phrases, and clauses to connect your ideas and to clarify the relationships among claims, counterclaims, reasons, and evidence.
- Establish and maintain a formal style.
- Provide a concluding statement or section that follows from and supports the argument presented.
- Check your work for correct usage, grammar, spelling, capitalization, and punctuation.

A large rectangular box with a black border, containing 30 horizontal lines for writing. The lines are evenly spaced and extend across most of the width of the box.

Unit 5: Language

CONTENT DESCRIPTION

The language portion of the English Language Arts test focuses on the use of proper grammar, punctuation, spelling, and usage.

Language

- You need to express yourself clearly and in an interesting way.
- Choose your words carefully so your readers understand what you are writing.
- Apply the rules of grammar as you write.

Conventions of Standard English

- Use correct grammar and usage when writing.
- Use correct capitalization, punctuation, and spelling.

Style

- Vary the words you use. Use a dictionary and thesaurus to help you.
- Your writing should be clear and interesting at the same time.
- Use colorful language and different sentence structures.

KEY TERMS

Misplaced modifier: A word, phrase, or clause that is improperly separated from the word it modifies/describes. For example, *I found a gold woman's necklace on the sidewalk*. In this sentence, *gold* is a misplaced modifier. This sentence makes it sound like the woman, instead of the necklace, was gold. (L1c)

Dangling modifier: A phrase or clause that is not clearly and logically related to the word or words it modifies. For example, *Fixed last night, Abby could use her car*. In this sentence, *Fixed last night* is a dangling modifier. The sentence makes it sound like Abby, instead of her car, was fixed last night. (L1c)

Punctuation: Writing marks that help to separate and clarify ideas. Examples of punctuation are the period, comma, colon, exclamation mark, and question mark. (L2)

Coordinate adjectives: Adjectives that appear in a sequence to modify the same noun. For example, *it was a bright, sunny day*. Coordinate adjectives usually need a comma to separate them. (L2a)

Redundancy: Using a phrase or word that repeats something else and is unnecessary. Writers should be concise and precise, thereby avoiding redundancy. (L3a)

Context: Words and phrases that surround another phrase and help to explain its meaning. Sometimes a word cannot be understood without the context of the words and phrases around it. For example, *he threw it* could mean several things, but when the full sentence is included, *He threw the basketball up high from midcourt and sunk it through the hoop for two points*, the meaning is clear. (L4a)

Root: The foundation of a word. Knowing the meaning of the root can help a reader determine the meaning of its variations. For example, if you know that a “school” is a place that provides knowledge, you may be able to guess that “scholar” is someone who is seeking knowledge. (L4b)

Allusion: An indirect reference to something. When a writer refers to something without mentioning it explicitly, it is an allusion. For example, *He didn’t want to give gifts to anyone at Christmas; he was being a scrooge*. In this sentence, the writer is alluding to Ebenezer Scrooge from Charles Dickens’ *A Christmas Carol*. (L5a)

Figurative Language:

- **Personification:** When a writer describes an object as if it were a person. For example, *The trees sighed in the afternoon breeze*. The trees can’t really sigh but seemed to as they blew gently in the breeze. (L5a)
- **Simile:** A comparison using *like* or *as*. For example, *She is as pretty as a picture*. (L5a)
- **Metaphor:** A direct comparison that states one thing *is* another. It isn’t meant to be literal, but descriptive. For example, *He is an animal on the soccer field* does not mean that the boy is really an animal, but it is a metaphor for how he plays soccer (very aggressively). (L5a)

Analogy: A comparison of two things that are somehow alike. For example, *Just like soldiers use weapons, writers use pens*. This analogy compares pens to weapons. Analogies can employ both **similes** and **metaphors**. (L5b)

Denotation and connotation: A **connotation** is an implied meaning—it is the meaning the writer intends, which may not be the same thing as the literal or dictionary meaning of a word. **Denotation** is the exact definition of a word. Words can have different connotations depending on how they are used. For example, *polite* and *diplomatic* have similar denotations (respectful, courteous) but can have different connotations (*polite* is more positive, while *diplomatic* connotes that the respectful behavior may be masking other true feelings). (L5c)

Important Tips

- ✍ To study for this part of the EOG assessment, concentrate on the kinds of errors you typically make in your own writing. Then review grammar rules for those specific kinds of errors. Use books or free online resources to find practice items that you can try. You can work with a partner and question each other on grammar rules or try editing sentences together. Focus your review time on strengthening the areas or skills that need it the most.
- ✍ When you are faced with an unknown word, go back to the passage. Start reading two sentences before the word appears, and continue reading for two sentences afterward or elsewhere in the passage to understand the context of how the word is being used.

Sample Items 17–20

Item 17

The sentence below has a spelling error.

In the laboratory, we set up the apparatus efficiently in aproximately 10 minutes.

Which word is **NOT** spelled correctly?

- A. laboratory
- B. apparatus
- C. efficiently
- D. aproximately

Item 18

Based on the word parts, what is the meaning of *universal* in the sentence?

They want to know why some stories receive universal acceptance, and others do not.

- A. possible
- B. regular
- C. common
- D. serious

Item 19

Which sentence uses commas correctly?

- A. She was happy with the quick, satisfying results.
- B. The group decided to stage the old, original, play.
- C. They painted the old barn with a bright, red paint.
- D. We went to the beach and built a sturdy, sand tower.

Item 20

Which sentence contains an error between the relationship of ideas?

- A. Coming home late, they went straight to bed.
- B. Walking in the door, the lights were turned on.
- C. Without being warned, we heard them yell, "Surprise!"
- D. Showing up late is still better than not showing up at all.

ENGLISH LANGUAGE ARTS (ELA) ADDITIONAL SAMPLE ITEM KEYS

Item	Standard/ Element/ Genre	DOK Level	Correct Answer	Explanation
1	ELAGSE7RL2 Literary	2	B	The correct answer is choice (B) A worldly but private man is difficult to get to know. The author makes clear in the text that Phileas Fogg knows a great deal about the world but is all but unknown to those who interact with and observe him. Choices (A), (C), and (D) are all contradicted by the text. Choice (A) is contradicted by the details of Phileas dining at his gentleman’s club. Choice (C) is contradicted by the details that suggest no one knows for sure how Phileas has come by his worldly knowledge, so he can’t have been boasting. Choice (D) is contradicted by the passage, which says that Phileas’s daily habits were “quite open to observation.”
2	ELAGSE7RL3 Literary	2	D	The correct answer is choice (D) He prefers his own company to that of others. The focus of the entire passage is on how Phileas Fogg is a worldly man whom no one knows well. Fogg seems not to have any problems with his acquaintances, so Choice (B) is incorrect. Nor does he have trouble giving money to those who need it, so choice (A) is incorrect. The details of the passage suggest that Phileas is quite at ease in his own skin, so choice (C) is also incorrect.
3	ELAGSE7L4	2	C	The correct answer is choice (C) servant. A domestic is a servant, such as a maid, butler, or housekeeper. Choice (A) is incorrect because <i>local</i> is someone from a nearby place. Choice (B) is incorrect because a native is someone who is born in a certain place. Choice (D) is incorrect because a domestic is someone within a household, not an outsider.
4	ELAGSE7W3a	4	N/A	See scoring rubric beginning on page 63 and sample response on page 54.

Item	Standard/ Element/ Genre	DOK Level	Correct Answer	Explanation
5	ELAGSE7RI2 Informational/ Explanatory	2	D	The correct answer is choice (D) The federal government created jobs for unemployed artists, musicians, and writers. The author describes four specific programs that provided employment for people during the Great Depression. Choice (A) may possibly be true for some people who learned more about their roots, but the passage explicitly states that the federal works projects helped Americans realize the value of their diverse culture and traditions. Choice (B) is incorrect because although the passage does say that some art can still be seen on some post office walls, it does not imply that most modern post offices contain art produced during the Great Depression. Choice (C) is a true statement, but it is not the most important idea to include in a summary of this passage.
6	ELAGSE7RI1 Informational/ Explanatory	2	A	The correct answer is choice (A) to provide artists, musicians, and writers with employment. The purpose was to find work for struggling artists. Choice (B) is incorrect because Roosevelt wanted all citizens working and not just government employees. Choice (C) is incorrect because the emphasis of the federal programs was to employ people; awareness of the importance of American cultural traditions was a secondary outcome. Choice (D) is incorrect because the passage suggests that increased national pride via the arts was an effect of the employment of out-of-work artists, not Roosevelt's stated goal.
7	ELAGSE7RI5 Informational/ Explanatory	3	N/A	See scoring rubric and sample response on page 55.
8	ELAGSE7RI3 Informational/ Explanatory	2	N/A	See scoring rubric and sample response beginning on page 56.
9	ELAGSE7W2e	2	B	The correct answer is choice (B) I recommend that potential exchange students read about others' experiences before applying. It is the only answer choice that consistently uses formal and academic language. The other choices use colloquial expressions, slang, and contractions. Choice (A) uses <i>totally</i> and <i>awesome</i> . Choice (C) uses <i>super</i> . Choice (D) uses <i>topsy-turvy</i> and <i>wouldn't</i> .

Item	Standard/ Element/ Genre	DOK Level	Correct Answer	Explanation
10	ELAGSE7W2f	2	D	The correct answer is choice (D) Your visit might last a year, but your memories will last a lifetime. It is the only answer choice that sums up the writer's thoughts about being an exchange student. Choice (A) is more appropriate for a body paragraph in which the two places are compared and contrasted. Choice (B) would fit better in the opening paragraph because it identifies a first step in the process of becoming an exchange student. Choice (C) might be better at the end of the section about the causes and symptoms of culture shock.
11	ELAGSE7RI1 Informational/ Explanatory	3	N/A	See scoring rubric and sample response on page 58.
12	ELAGSERI3 Informational/ Explanatory	2	N/A	See scoring rubric and sample response on page 59.
13	ELAGSE7W1A	2	D	The correct answer is choice (D) To ignore the studies that show underwater noise does have an impact is perhaps selfish. It is the only answer choice that acknowledges there is an opposite point of view. Choice (A) reinforces the author's claim that we should reduce underwater noise. Choice (B) restates the author's claim in the final paragraph. Choice (C) adds nothing to the final paragraph.
14	ELAGSE7RI1 Informational/ Explanatory	2	B	The correct answer is choice (B) No whales changed their overall behaviors in response to sonar activity. Choice (A) is incorrect because it only partly explains the beaked whales' reactions during the Navy's study. Choice (C) is incorrect because it states a finding that does not support the Navy's claim. Choice (D) is incorrect because the statement is irrelevant to the Navy's claim about its study.
15	ELAGSE7RI8 Informational/ Explanatory	3	N/A	See scoring rubric and sample response on page 60.
16	ELAGSE7W1	4	N/A	See scoring rubric beginning on page 67 and sample response on page 61.
17	ELAGSE7L2b	2	D	The correct answer is choice (D) approximately. The word should be spelled "approximately." Choices (A), (B), and (C) are all spelled correctly.

Item	Standard/ Element/ Genre	DOK Level	Correct Answer	Explanation
18	ELAGSE7L4b	2	C	The correct answer is choice (C) common. It comes from the Latin root word “uni,” meaning “one” or “whole.” The word “universe” refers to all that exists, so by extension “universal” means common to all. Choices (A), (B), and (D) are not the correct meanings of the word.
19	ELAGSE7L2a	2	A	The correct answer is choice (A) She was happy with the quick, satisfying results. A comma is used to separate coordinate adjectives. Choice (B) is incorrect. The comma between “old” and “original” is correct, but there should not be a comma between “original” and “play.” Choice (C) is incorrect because a comma is not required between the adjectives “bright” and “red.” Choice (D) is incorrect because a comma does not belong between “sturdy” and “sand.”
20	ELAGSE7L1c	2	B	The correct answer is choice (B) Walking in the door, the lights were turned on. This is written incorrectly because the modifier is misplaced. The “lights” are not the subject of the sentence—they are not walking in the door. Choice (A) is written correctly. The clauses in this sentence are written correctly. Choice (C) is written correctly without a misplaced modifier. Choice (D) is written correctly. The clauses in this sentence are written correctly.

ENGLISH LANGUAGE ARTS (ELA) SAMPLE SCORING RUBRICS AND EXEMPLAR RESPONSES

Item 4

The following is an example of a four-point response. See the rubric for a text-based narrative response on pages 63 and 64 to see why this example would earn the maximum number of points.

Example of a Four-Point Response:

My name is Phileas Fogg. I live at No. 7 Saville Row, Burlington Gardens. It is the very house in which the great writer Sheridan died in 1814. I was not there, of course. I was not even born then. I belong to the Reform Club. People act as if they know and respect me, but they actually know very little about me. I keep to myself. I prefer books to human companionship, although I have traveled extensively around the world. People consider me to be a gentleman who looks like a famous poet. I don't see the resemblance, myself.

I have enough money to live in a fine home and own lovely things, but I don't make a big deal of them. I am not a recluse either. I am out and about on the streets of London or any city that I visit, where people can observe me openly. I am watching them as well. It's a silly kind of game, but I enjoy watching people who think they know and understand me. I let them think what they wish, and then I go back home or to the club where I eat well and think about what I have read or seen that day. It is a wonderful life. I wouldn't change it for the world.

Item 7

Scoring Rubric

Points	Description
2	The exemplar shows a full-credit response. It achieves the following: <ul style="list-style-type: none"> • Gives sufficient evidence of the ability to analyze the structure of the passage • Includes specific examples/details that make clear reference to the text • Adequately explains the purpose of the structure with details based on the text
1	The exemplar shows a 1-point response. It achieves the following: <ul style="list-style-type: none"> • Gives limited evidence of the ability to analyze the structure of the passage • Includes limited examples that make reference to the text • Explains the purpose of the structure with vague/limited details based on the text
0	The exemplar shows a response that would earn no credit. It achieves the following: <ul style="list-style-type: none"> • Gives no evidence of the ability to analyze the structure of the passage

Exemplar Response

Points Awarded	Sample Response
2	The passage is an informative text that uses problem and solution to present its information. The passage begins by providing historical context about the Great Depression and President Roosevelt’s efforts to provide employment for millions of jobless workers. It then describes four federal programs—the Federal Arts Project, the Federal Theater Project, the Federal Music Project, and the Federal Writers’ Project. It provides a paragraph about each of these programs, explaining how each of the projects created a solution to the economic problems at that time. Each paragraph provides details about how the program helped put specific people—artists, musicians, actors, and writers—back to work during the Great Depression. The text concludes by suggesting that the federal projects not only helped Americans get back on their feet economically but also reminded them of their great cultural heritage. In this way, the structure and organization of the passage shaped the way the author developed the ideas in the text.
1	The passage begins by telling about the Great Depression and the high unemployment in the United States. It then goes on to describe four federal programs that the President put in place to put artists, musicians, actors, and writers back to work. The passage is organized by stating the problem and the solution. Then the passage gives lots of details about some of the programs, including how many workers had jobs and what they did.
0	The passage tells about programs that were created during the Great Depression. They created jobs for people. Some were painters. Some were writers and musicians. The passage also gives information about Franklin Delano Roosevelt, who was president at the time.

Item 8**Scoring Rubric**

Points	Description
2	The exemplar shows a full-credit response. It achieves the following: <ul style="list-style-type: none">• Gives sufficient evidence of the ability to identify causes and effects• Includes specific examples/details that make clear reference to the text• Adequately explains the purpose of the structure with details based on the text
1	The exemplar shows a 1-point response. It achieves the following: <ul style="list-style-type: none">• Gives limited evidence of the ability to identify causes and effects• Includes limited examples that make reference to the text• Explains the purpose of the structure with vague/limited details based on the text
0	The exemplar shows a response that would earn no credit. It achieves the following: <ul style="list-style-type: none">• Gives no evidence of the ability to identify causes and effects

Exemplar Response

Points Awarded	Sample Response
2	<p>In the 1930s, Americans were suffering economically from the Great Depression. Many Americans were out of work, and artists suffered more than most. In an attempt to employ many creative types of people—including writers, actors, musicians, and painters—the president created several programs beginning in 1935. The programs not only provided employment opportunities for these people but they also helped Americans recognize their own cultural wealth. Each of the programs had the same purpose—to provide jobs for unemployed people. The Federal Arts program encouraged artists to design and paint murals on public buildings. The Federal Theater Project provided playwrights and actors with the means to put together theatrical productions that they could show to audiences around the nation, for free. The Federal Music Project gave jobs to musicians, including composers and instrumentalists. The Federal Writers’ Project hired many writers to travel across the country to record people’s oral histories, songs, and lore. The results are forever preserved at the Library of Congress.</p>
1	<p>President Franklin Delano Roosevelt got the idea for creating new programs that would put people back to work during the Great Depression. The whole country was suffering, and Roosevelt helped creative people by giving them jobs painting murals on public buildings or writing and performing plays or recording music. The murals were a lot like the murals in Mexico, except these were on post offices. They showed scenes of the American people and where they lived. The Depression had hit the country hard, and not only did the artists need work, but people needed to appreciate their own culture. The four programs Roosevelt created, even though they did not last long, helped do both those things. They had a great impact at the time of the Great Depression.</p>
0	<p>President Franklin Delano Roosevelt started the programs during the Great Depression, when many people were out of work. Some people painted post offices. Some people built bridges. Some people recorded people telling stories.</p>

Item 11**Scoring Rubric**

Points	Description
2	<p>The exemplar shows a full-credit response. It achieves the following:</p> <ul style="list-style-type: none"> • Gives sufficient evidence of the ability to analyze what the text says explicitly as well as draw inferences from a text • Adequately supports the analysis of what the text says with evidence from the text • Includes specific evidence from the text
1	<p>The exemplar shows a 1-point response. It achieves the following:</p> <ul style="list-style-type: none"> • Gives limited evidence of the ability to analyze what the text says explicitly as well as draw inferences from a text • Supports the analysis of what the text says with evidence from the text • Includes vague/limited evidence from the text
0	<p>The exemplar shows a response that would earn no credit. It achieves the following:</p> <ul style="list-style-type: none"> • Gives no evidence of the ability to analyze what the text says

Exemplar Response

Points Awarded	Sample Response
2	<p>The author shows that culture shock is a part of the experience of living and studying abroad and includes personal experiences. There are three stages of culture shock—the honeymoon phase, the frustration stage, and the adoption stage. During the honeymoon stage, he or she was excited to see the monuments in the battlefield. During the frustration stage, he or she began to dislike the food and the weather in Pennsylvania. During the adoption stage, he or she began to realize the value of seeing differences in the world. The author thinks that culture shock helps exchange students understand their experiences.</p>
1	<p>The author supports the idea that culture shock is an essential part of the experience of living and studying abroad. The author tells about the three stages of culture shock. The author also refers to his or her own experiences as an exchange student.</p>
0	<p>The author went abroad from India for a year and learned about living in the United States. It was different from life at home in India.</p>

Item 12

Scoring Rubric

Points	Description
2	<p>The exemplar shows a full-credit response. It achieves the following:</p> <ul style="list-style-type: none"> • Gives sufficient evidence of the interaction between individuals, events, and ideas in a text • Adequately analyzes how ideas and events influence the individual and how the individual influences ideas in the text • Includes specific details that make clear reference to the text
1	<p>The exemplar shows a 1-point response. It achieves the following:</p> <ul style="list-style-type: none"> • Gives limited evidence of the interaction between individuals, events, and ideas in a text • Explains how ideas and events influence the individual and how the individual influences ideas in the text • Includes vague/limited details that makes reference to the text
0	<p>The exemplar shows a response that would earn no credit. It achieves the following:</p> <ul style="list-style-type: none"> • Gives no evidence of the interaction between the individual and ideas and events in a text

Exemplar Response

Points Awarded	Sample Response
2	<p>The author describes living in both India and the United States and how the experience of first living in Mumbai then coming to the US affected him. The author prefers Mumbai, with its crowds, hot weather, and hot, spicy food. Mumbai was busy and exciting and nothing like Gettysburg. The author says, "If my host family had lived in NYC, I might have had an easier time adjusting." After being in the US for a while, the author does start to feel differently about Gettysburg and appreciates what it has to offer. But the cold weather, the bland food, and the size of the city make him miss Mumbai. His experiences living in the United States might have been different if the author had not lived in Mumbai first.</p>
1	<p>The author likes living in Mumbai and he had trouble adjusting to living in the United States. Mumbai is big and has many more people than Gettysburg. The weather in the two cities is very different, and the author did not like the winter. Too cold and wet. The author did not like the food in Gettysburg. He thought the spicy, varied food of Mumbai was better. He liked being an exchange student and yet there were many things he did not like.</p>
0	<p>The author should have studied in New York City because it is big like Mumbai.</p>

Item 15

Scoring Rubric

Points	Description
2	<p>The exemplar shows a full-credit response. It achieves the following:</p> <ul style="list-style-type: none"> • Gives sufficient evidence to evaluate whether reasoning is sound and evidence is relevant to the central argument in a text • Adequately explains whether the reasoning is sound and evidence is relevant to the central argument found in a text • Includes specific evidence that make clear reference to the text
1	<p>The exemplar shows a 1-point response. It achieves the following:</p> <ul style="list-style-type: none"> • Gives limited evidence to evaluate whether reasoning is sound and evidence is relevant to the central argument in a text • Explains whether the reasoning is sound and evidence is relevant to the central argument in a text • Includes vague/limited evidence that makes reference to the text
0	<p>The exemplar shows a response that would earn no credit. It achieves the following:</p> <ul style="list-style-type: none"> • Gives no evidence to evaluate if evidence is relevant to the central argument in a text

Exemplar Response

Points Awarded	Sample Response
2	<p>The author of “What Underwater Noise?” is making the argument that noise does not negatively affect sea creatures. The quotation telling about one study’s conclusion that sonar activity caused one species of whale to change its behavior actually supports the opposing argument. So this quotation is not relevant and does not support the author’s main argument. By including this quotation, the author of the second passage is suggesting that some support may actually exist for the opinion of the author of the first passage—as well as suggesting that there may be some value in the study itself.</p>
1	<p>The author of “What Underwater Noise?” says that we don’t need to worry about reducing noise in the world’s oceans. The quotation supports the opposite opinion.</p>
0	<p>The author says noise is not a problem.</p>

Item 16

The following is an example of a seven-point response. See the seven-point, two-trait rubric for a text-based argumentative response on pages 67 and 68 to see why this example would earn the maximum number of points.

Example of a Seven-Point Response:

For several decades, Americans have been more aware of the pollution they create. They understand that air gets polluted by emissions from our cars, planes, and other equipment. Water gets polluted by emissions and by use of fertilizers on our lawns and fields. The ground gets polluted by oil run-off from our roads and the trash we throw away. There is also light pollution—the light created by our streetlights and store signs creates a glare that makes it seem as if it is always daytime. And noise pollution occurs in places where there is constant machine activity, such as city streets and even under the ocean. Scientists today are worried that animals are really suffering because of the pollution we humans have created. They say we are causing all kinds of animals to go extinct. It would be good to be more thoughtful about the pollution we create in order to preserve the world’s animals.

Noise pollution is one big issue in the world’s oceans. Underwater noise pollution is the result of human activity in the water—ships transporting goods around the world, submarines patrolling the waters, and oil refineries drilling and processing oil from beneath the ocean’s floor. The noise doesn’t bother us humans because we can’t hear it, but scientists say that it is upsetting some underwater creatures, especially whales. Some studies have shown that some particular species of whales, including beaked whales, pilot whales, and melon-headed whales, respond negatively to underwater noise. It caused some whales to change their behaviors. Some scientists argue that in particular Navy sonar activities, which use sound waves to explore the ocean, cause the whales to have communication problems. Yet, a Navy study done with other marine life experts has shown no such results. The Navy has argued that as a result it should be allowed to continue its activities.

While there are studies that suggest that animals are not affected by the noise and other kinds of pollution we create, it is not a good idea for anybody to have to live in a polluted environment—humans or animals. Everyone, including the world’s animals would be better off if we cut back on the use of fossil fuels and other activities that make the world a dirtier, noisier place.

ENGLISH LANGUAGE ARTS (ELA) WRITING RUBRICS

Grade 7 items that are not machine-scored—i.e., constructed-response, extended constructed-response, and extended writing response items—are manually scored using either a holistic rubric or a two-trait rubric.

Four-Point Holistic Rubric

Genre: Narrative

A holistic rubric evaluates one major feature, which is ideas. On the Georgia Milestones EOG assessment, a holistic rubric is scored from zero to four. Each point value represents the difference in the levels or quality of the student's work. To score an item on a holistic rubric, the scorer need only choose the description and associated point value that best represents the student's work. Increasing point values represent a greater understanding of the content and, thus, a higher score.

Seven-Point, Two-Trait Rubric

Genre: Argumentative or Informational/Explanatory

A two-trait rubric, on the other hand, evaluates two major traits, which are conventions and ideas. On the Georgia Milestones EOG assessment, a two-trait rubric contains two scales, one for each trait, ranging from zero to three on one scale (conventions) and zero to four on the other (ideas). A score is given for each of the two traits, for a total of seven possible points for the item. To score an item on a two-trait rubric, a scorer must choose the description and associated point value for each trait that best represents the student's work. The two scores are added together. Increasing point values represent a greater understanding of the content and, thus, a higher score.

On the following pages are the rubrics that will be used to evaluate writing on the Georgia Milestones Seventh Grade English Language Arts EOG assessment.

Four-Point Holistic Rubric

Genre: Narrative

Writing Trait	Points	Criteria
<p><i>This trait examines the writer's ability to effectively develop real or imagined experiences or events using effective techniques, descriptive details, and clear event sequences based on a text that has been read.</i></p>	4	<p><i>The student's response is a well-developed narrative that fully develops a real or imagined experience based on text as a stimulus.</i></p> <ul style="list-style-type: none"> • Effectively establishes a situation and point of view and introduces a narrator and/or characters • Organizes an event sequence that unfolds naturally and logically • Effectively uses narrative techniques, such as dialogue, description, and pacing, to develop rich, interesting experiences, events, and/or characters • Uses a variety of words and phrases to convey the sequence of events and signal shifts in one time frame or setting to another • Uses precise words, phrases, and sensory language consistently and effectively to convey experiences or events and capture the action • Provides a conclusion that follows from the narrated experiences or events • Integrates ideas and details from source material effectively • Has very few or no errors in usage and/or conventions that interfere with meaning*
	3	<p><i>The student's response is a complete narrative that develops a real or imagined experience based on text as a stimulus.</i></p> <ul style="list-style-type: none"> • Establishes a situation and introduces one or more characters • Organizes events in a clear, logical order • Uses narrative techniques, such as dialogue, description, and pacing, to develop experiences, events, and/or characters • Uses words and/or phrases to indicate sequence of events and signal shifts in one time frame or setting to another • Uses words, phrases, and details to capture the action and convey experiences and events • Provides an appropriate conclusion • Integrates some ideas and/or details from source material • Has a few minor errors in usage and/or conventions that interfere with meaning*

Four-Point Holistic Rubric

**Genre: Narrative
(continued)**

Writing Trait	Points	Criteria
<p><i>This trait examines the writer’s ability to effectively develop real or imagined experiences or events using effective techniques, descriptive details, and clear event sequences based on a text that has been read.</i></p>	2	<p><i>The student’s response is an incomplete or oversimplified narrative based on text as a stimulus.</i></p> <ul style="list-style-type: none"> • Introduces a vague situation and at least one character • Organizes events in a sequence but with some gaps or ambiguity • Attempts to use some narrative technique, such as dialogue, description, and pacing, to develop experiences, events, and/or characters • Uses occasional signal words inconsistently and ineffectively to indicate sequence of events and signal shifts in one time frame or setting to another • Uses some words or phrases inconsistently and ineffectively to convey experiences and events and capture the action • Provides a weak or ambiguous conclusion • Attempts to integrate ideas or details from source material • Has frequent errors in usage and conventions that sometimes interfere with meaning*
	1	<p><i>The student’s response provides evidence of an attempt to write a narrative based on text as a stimulus.</i></p> <ul style="list-style-type: none"> • Response is a summary of the story • Provides a weak or minimal introduction of a situation or character • May be too brief to demonstrate a complete sequence of events or signal shifts in one time frame or setting to another • Shows little or no attempt to use dialogue, description, and pacing to develop experiences, events, and/or characters • Uses words that are inappropriate, overly simple, or unclear • Provides few, if any, words that convey experiences, or events, or signal shifts in one time frame or setting to another • Provides a minimal or no conclusion • May use few, if any, ideas or details from source material • Has frequent major errors in usage and conventions that interfere with meaning*
	0	<p><i>The student’s response is flawed for various reasons and will receive a condition code:</i></p> <ul style="list-style-type: none"> • Code A: Blank • Code B: Copied • Code C: Too Limited to Score/Illegible/Incomprehensible • Code D: Non-English/Foreign Language • Code E: Off Topic/Off Task/Offensive

*Students are responsible for language conventions learned in their current grade as well as in prior grades. Refer to the language skills for each grade to determine the grade-level expectations for grammar, syntax, capitalization, punctuation, and spelling. Also refer to the “Language Progressive Skills, by Grade” chart in Appendix A for those standards that need continued attention beyond the grade in which they were introduced.

Seven-Point, Two-Trait Rubric

Trait 1 for Informational/Explanatory Genre

Writing Trait	Points	Criteria
<p>Idea Development, Organization, and Coherence</p> <p><i>This trait examines the writer's ability to effectively establish a controlling idea and to support the idea with evidence from the text(s) read and to elaborate on the idea with examples, illustrations, facts, and other details in order. The writer must integrate the information from the text(s) into his/her own words and arrange the ideas and supporting evidence (from text that they have read) in order to create cohesion for an informative/explanatory essay.</i></p>	4	<p><i>The student's response is a well-developed informative/explanatory text that examines a topic in depth and conveys ideas and information clearly based on text as a stimulus.</i></p> <ul style="list-style-type: none"> • Effectively introduces a topic • Effectively organizes ideas, concepts, and information using various strategies such as definition, classification, comparison/contrast, and cause/effect • Effectively develops the topic with multiple, relevant facts, definitions, concrete details, quotations, or other information and examples related to the topic • Effectively uses appropriate transitions to create cohesion and clarify the relationships among ideas and concepts • Uses precise language and domain-specific vocabulary to inform about or explain the topic • Establishes and maintains a formal style • Provides a strong concluding statement or section that follows from the information or explanation presented
	3	<p><i>The student's response is a complete informative/explanatory text that examines a topic and presents information based on a text as a stimulus.</i></p> <ul style="list-style-type: none"> • Introduces a topic • Generally organizes ideas, concepts, and information • Develops the topic with a few facts, definitions, concrete details, quotations, or other information and examples • Uses some transitions to connect and clarify relationships among ideas, but relationships may not always be clear • Uses some precise language and domain-specific vocabulary to explain the topic • Maintains a formal style, for the most part • Provides a concluding statement or section
	2	<p><i>The student's response is an incomplete or oversimplified informative/explanatory text that cursorily examines a topic.</i></p> <ul style="list-style-type: none"> • Attempts to introduce a topic • Attempts to develop a topic with too few details • Ineffectively organizes ideas, concepts, and information • Uses limited language and vocabulary that does not inform or explain the topic • Uses few transitions to connect and clarify relationships among ideas • Uses a formal style inconsistently or uses an informal style • Provides a weak concluding statement or section
	1	<p><i>The student's response is a weak attempt to write an informative/explanatory text that examines a topic.</i></p> <ul style="list-style-type: none"> • May not introduce a topic, or topic is unclear • May not develop a topic • May be too brief to group any related ideas together • May not use any linking words to connect ideas • Uses vague, ambiguous, or repetitive language • Uses a very informal style • Provides a minimal or no concluding statement or section
	0	<p><i>The student's response is flawed for various reasons and will receive a condition code:</i></p> <ul style="list-style-type: none"> • Code A: Blank • Code B: Copied • Code C: Too Limited to Score/Illegible/Incomprehensible • Code D: Non-English/Foreign Language • Code E: Off Topic/Off Task/Offensive

Seven-Point, Two-Trait Rubric

Trait 2 for Informational/Explanatory Genre

Writing Trait	Points	Criteria
<p>Language Usage and Conventions</p> <p><i>This trait examines the writer’s ability to demonstrate control of sentence formation, usage, and mechanics as embodied in the grade-level expectations of the language standards.</i></p>	3	<p><i>The student’s response demonstrates full command of language usage and conventions.</i></p> <ul style="list-style-type: none"> • Effectively varies sentence patterns for meaning, reader/listener interest, and style • Shows command of language and conventions when writing • Any errors in usage and conventions do not interfere with meaning*
	2	<p><i>The student’s response demonstrates partial command of language usage and conventions.</i></p> <ul style="list-style-type: none"> • Varies some sentence patterns for meaning, reader/listener interest, and style • Shows some knowledge of languages and conventions when writing • Has minor errors in usage and conventions with no significant effect on meaning*
	1	<p><i>The student’s response demonstrates weak command of language usage and conventions.</i></p> <ul style="list-style-type: none"> • Has fragments, run-ons, and/or other sentence structure errors • Shows little knowledge of languages and conventions when writing • Has frequent errors in usage and conventions that interfere with meaning*
	0	<p><i>The student’s response is flawed for various reasons and will receive a condition code:</i></p> <ul style="list-style-type: none"> • Code A: Blank • Code B: Copied • Code C: Too Limited to Score/Illegible/Incomprehensible • Code D: Non-English/Foreign Language • Code E: Off Topic/Off Task/Offensive

*Students are responsible for language conventions learned in their current grade as well as in prior grades. Refer to the language skills for each grade to determine the grade-level expectations for grammar, syntax, capitalization, punctuation, and spelling. Also refer to the “Language Progressive Skills, by Grade” chart in Appendix A for those standards that need continued attention beyond the grade in which they were introduced.

Seven-Point, Two-Trait Rubric

Trait 1 for Argumentative Genre

Writing Trait	Points	Criteria
<p>Idea Development, Organization, and Coherence</p> <p><i>This trait examines the writer's ability to effectively establish a claim as well as to address counterclaims, to support the claim with evidence from the text(s) read, and to elaborate on the claim with examples, illustrations, facts, and other details. The writer must integrate the information from the text(s) into his/her own words and arrange the ideas and supporting evidence in order to create cohesion for an argument essay.</i></p>	4	<p><i>The student's response is a well-developed argument that effectively relates and supports claims with clear reasons and relevant text-based evidence.</i></p> <ul style="list-style-type: none"> • Effectively introduces claim(s) • Uses an organizational strategy to clearly present reasons and relevant evidence logically • Supports claim(s) with clear reasons and relevant evidence using specific, well-chosen facts, details, or other information from credible sources and demonstrates a good understanding of the topic or texts • Acknowledges and counters opposing claim(s), as appropriate • Uses words, phrases, and/or clauses that effectively connect and show direct, strong relationships among claim(s), reasons, and evidence • Establishes and maintains a formal style that is appropriate for task, purpose, and audience • Provides a strong concluding statement or section that logically follows from the argument presented
	3	<p><i>The student's response is a complete argument that develops and supports claims with some text-based evidence.</i></p> <ul style="list-style-type: none"> • Clearly introduces claim(s) • Uses an organizational strategy to present reasons and evidence • Uses facts, details, definitions, examples, and/or other information to develop claim(s) • Attempts to acknowledge and/or counter opposing claim(s), as appropriate • Uses words, phrases, or clauses that connect and show relationships among claim(s), reasons, and evidence • Uses a formal style fairly consistently that is appropriate for task, purpose, and audience • Provides a concluding statement or section that follows from the argument presented
	2	<p><i>The student's response is an incomplete or oversimplified argument that partially supports claims with loosely related text-based evidence.</i></p> <ul style="list-style-type: none"> • Attempts to introduce claim(s) • Attempts to use an organizational structure which may be formulaic • Attempts to support claim(s) with facts, reasons, and other evidence sometimes, but logic and relevancy are often unclear • Makes little, if any, attempt to acknowledge or counter opposing claim(s) • Uses few words, phrases, or clauses to connect ideas; connections are not always clear • Uses a formal style inconsistently or an informal style that does not fit task, purpose, or audience • Provides a weak concluding statement or section that may not follow the argument presented
	1	<p><i>The student's response is a weak attempt to write an argument and does not support claims with adequate text-based evidence.</i></p> <ul style="list-style-type: none"> • May not introduce claim(s)/claim(s), or they must be inferred • May be too brief to demonstrate an organizational structure, or no structure is evident • Has minimal support for claim(s) • Makes no attempt to acknowledge or counter opposing claim(s) • Uses minimal or no words, phrases, or clauses to connect ideas • Uses very informal style that is not appropriate for task, purpose, or audience • Provides a minimal or no concluding statement or section
	0	<p><i>The student's response is flawed for various reasons and will receive a condition code:</i></p> <ul style="list-style-type: none"> • Code A: Blank • Code B: Copied • Code C: Too Limited to Score/Illegible/Incomprehensible • Code D: Non-English/Foreign Language • Code E: Off Topic/Off Task/Offensive

Seven-Point, Two-Trait Rubric

Trait 2 for Argumentative Genre

Writing Trait	Points	Criteria
<p>Language Usage and Conventions</p> <p><i>This trait examines the writer’s ability to demonstrate control of sentence formation, usage, and mechanics as embodied in the grade-level expectations of the language standards.</i></p>	3	<p><i>The student’s response demonstrates full command of language usage and conventions.</i></p> <ul style="list-style-type: none"> • Effectively varies sentence patterns for meaning, reader/listener interest, and style • Shows command of language and conventions when writing • Any errors in usage and conventions do not interfere with meaning*
	2	<p><i>The student’s response demonstrates partial command of language usage and conventions.</i></p> <ul style="list-style-type: none"> • Varies some sentence patterns for meaning, reader/listener interest, and style • Shows some knowledge of languages and conventions when writing • Has minor errors in usage and conventions with no significant effect on meaning*
	1	<p><i>The student’s response demonstrates weak command of language usage and conventions.</i></p> <ul style="list-style-type: none"> • Has fragments, run-ons, and/or other sentence structure errors • Shows little knowledge of languages and conventions when writing • Has frequent errors in usage and conventions that interfere with meaning*
	0	<p><i>The student’s response is flawed for various reasons and will receive a condition code:</i></p> <ul style="list-style-type: none"> • Code A: Blank • Code B: Copied • Code C: Too Limited to Score/Illegible/Incomprehensible • Code D: Non-English/Foreign Language • Code E: Off Topic/Off Task/Offensive

*Students are responsible for language conventions learned in their current grade as well as in prior grades. Refer to the language skills for each grade to determine the grade-level expectations for grammar, syntax, capitalization, punctuation, and spelling. Also refer to the “Language Progressive Skills, by Grade” chart in Appendix A for those standards that need continued attention beyond the grade in which they were introduced.

ACTIVITY

The following activity develops skills in Unit 1: Reading Literary Text.

Standards: ELAGSE7RL3, ELAGSE7RL9

Point of View

The story *Around the World in Eighty Days* is a fictional narrative. It is told from an outside narrator’s point of view. Point of view is how the narrator—the person who tells a story—presents the events of the story. The author’s choice of narrator and his or her words, thoughts, and feelings affect the story’s tone and mood.

To help you understand point of view, use the example of a classic children’s story, “The Three Little Pigs.” Traditional tales support lessons in point of view, because they are rarely told by someone within the story. The narrator is outside the story and he or she makes a clear distinction between the characters, who often represent good and evil. You can find the story on this site:

http://www.mightybook.com/free_to_read_text.php?book=Three_Little_Pigs-ftp

Even though the story is told by a narrator who is outside the story, he or she is sympathetic toward the pigs. The narrator tells the story in a way that makes readers prefer the pigs’ point of view to the wolf’s point of view.

The narrator creates sympathy for the pigs. The mood of the story is the overall feeling of the story. Words that describe the mood are **scary** and **suspenseful**. The mood is scary and suspenseful because the pigs are afraid of the wolf. He is threatening them. If the story had been told in a way that was sympathetic to the wolf, the mood would be very different.

Consider how the story would change if it were told from the wolf’s point of view or from a sympathetic narrator’s point of view. If possible, read *The True Story of the Three Little Pigs*, by Jon Scieszka. It is geared toward younger audiences, but, as is typical of fairy tales, it is entertaining to all ages, and it has multiple levels of meaning.

Choose a favorite fairy tale or folk tale. Rewrite it from a different character’s perspective.

ACTIVITY

The following activity develops skills in Unit 4: Writing: Argumentative Texts.

Standards: ELAGSE7W1, ELAGSE7W4, ELAGSE7W9

Writing Techniques

In the three-column chart below are different types of techniques and examples.

Techniques	Definition	Example
Repetition	Repeating a word or phrase twice or more times to highlight how important it is.	“Save paper, save plastic, save the world!”
Second Person	Using the pronoun <i>you</i> to address the readers or listeners directly to make them feel involved.	“You can help give these animals a happier life.”
Statistics	Using numbers to support your point.	“Over 80% of students think we should allow cell phones in class.”
Rhetorical Questions	Posing a question that does not require an answer.	“Why should we care about people who live on the other side of the world?”

The ability to identify bias is an important part of evaluating argumentative writing.

Find two organizations that might have opinions about ocean noise (environmental groups, scientific research groups, the Navy), and list the biases that might affect the writing of their members.

The following website will help you choose reliable, unbiased sources:

<http://ergo.slv.vic.gov.au/learn-skills/research-skills/select-resources/identify-bias>

MATHEMATICS

DESCRIPTION OF TEST FORMAT AND ORGANIZATION

The Grade 7 Mathematics EOG assessment consists of a total of 73 items.

You will answer a variety of item types on the test. Some of the items are selected-response (multiple-choice), which means you choose the correct answer from four choices. Some items will ask you to write your response.

The test will be given in two sections.

- You may have up to 85 minutes per section to complete Sections 1 and 2.
- The test will take about 120 to 170 minutes.

CONTENT

The Grade 7 Mathematics EOG assessment will measure the Grade 7 standards that are described at www.georgiastandards.org.

The content of the assessment covers standards that are reported under these domains:

- Ratios and Proportional Relationships
- The Number System
- Expressions and Equations
- Geometry
- Statistics and Probability

ITEM TYPES

The Mathematics portion of the Grade 7 EOG assessment consists of selected-response (multiple-choice) items, constructed-response items, and extended constructed-response items.

MATHEMATICS DEPTH OF KNOWLEDGE EXAMPLE ITEMS

Example items that represent applicable DOK levels of the Mathematics assessment are provided for you on the following pages. The items and explanations of what is expected of you to answer them will help you prepare for the test.

All example and sample items contained in this guide are the property of the Georgia Department of Education.

Example Item 1

DOK Level 1: This is a DOK level 1 item because it requires students to recall information about the order of operations.

Mathematics Grade 7 Content Domain II: Expressions and Equations

Standard: MGSE7.EE.3. Solve multistep, real-life, and mathematical problems posed with positive and negative rational numbers in any form (whole numbers, fractions, and decimals) by applying properties of operations as strategies to calculate with numbers, converting between forms as appropriate, and assessing the reasonableness of answers using mental computation and estimation strategies.

For example:

- *If a woman making \$25 an hour gets a 10% raise, she will make an additional $\frac{1}{10}$ of her salary an hour, or \$2.50, for a new salary of \$27.50.*
- *If you want to place a towel bar $9\frac{3}{4}$ inches long in the center of a door that is $27\frac{1}{2}$ inches wide, you will need to place the bar about 9 inches from each edge; this estimate can be used as a check on the exact computation.*

Simplify.

$$(2)(18) \div (-2 + 5)(-1)$$

- A. -13
- B. -12
- C. 12
- D. 13

Correct Answer: B

Explanation of Correct Answer: The correct answer is choice (B) -12. The order of operations was followed with the operations inside grouping symbols being completed first, followed by multiplying/dividing (left to right). Choice (A) is incorrect because after the expression inside the parentheses was evaluated, an incorrect quotient was calculated: $36 \div 3 \neq 13$. Choice (C) is incorrect because the -1 part of the expression was not applied or was applied incorrectly. Choice (D) is incorrect because the entire problem was worked left to right without regard to the order of operations.

Example Item 2

DOK Level 2: This is a DOK level 2 item because it assesses basic reasoning. Students must solve a problem demonstrating their understanding of multiplication of rational numbers.

Mathematics Grade 7 Content Domain I: The Number System

Standard: MGSE7.NS.2a. Apply and extend previous understandings of multiplication and division of fractions to multiply and divide rational numbers.

A football team loses 5 yards on each of 3 consecutive plays.

Part A: What signed number represents the team's total loss of yards on the 3 plays?

Part B: Explain how you found your answer.

<hr/> <hr/>

Scoring Rubric

Points	Description
2	<p>The response achieves the following:</p> <ul style="list-style-type: none"> • Response demonstrates a complete understanding of multiplication and division of rational numbers. • Give 2 points for Part A AND Part B correct. <ul style="list-style-type: none"> • Response is correct and complete. • Response shows application of a reasonable and relevant strategy. • Mathematical ideas are expressed coherently through a clear, complete, logical, and fully developed response using words, calculations, and/or symbols as appropriate.
1	<p>The response achieves the following:</p> <ul style="list-style-type: none"> • Response demonstrates a partial understanding of multiplication and division of rational numbers. • Give 1 point for Part A OR Part B correct. <ul style="list-style-type: none"> • Response is mostly correct but contains either a computation error or an unclear or incomplete explanation. • Response shows application of a relevant strategy, though it may be only partially applied or it may remain unexplained. • Mathematical ideas are expressed only partially using words, calculations, and/or symbols as appropriate.
0	<p>The response achieves the following:</p> <ul style="list-style-type: none"> • The response demonstrates limited to no understanding of multiplication and division of rational numbers. <ul style="list-style-type: none"> • Response is incorrect. • Response shows no application of a strategy. • Mathematical ideas cannot be interpreted or lack sufficient evidence to support even a limited understanding.

Exemplar Response

Points Awarded	Sample Response
2	<p>Part A: -15 yards (OR minus 15 yards OR negative 15 yards) Part B: I multiplied 3 times negative 5. I used a number line to show the multiplication by starting at 0 and moving 5 places to the left 3 times.</p>
1	<p>Part A: -15 yards (OR minus 15 yards OR negative 15 yards) Part B: I multiplied.</p>
0	<p><i>Response is irrelevant, inappropriate, or not provided.</i></p>

Example Item 3

DOK Level 3: This is a DOK level 3 item that assesses application of reasoning. Students have to apply their knowledge of calculating percentages to solve problems and explain the processes they used.

Mathematics Grade 7 Content Domain III: Ratios and Proportional Relationships

Standard: MGSE7.RP.3. Use proportional relationships to solve multistep ratio and percent problems. Examples: simple interest, tax, markups and markdowns, gratuities and commissions, and fees.

The selling price of a house dropped from \$250,000 to \$210,000 over a period of 5 years.

Part A: By what percent did the selling price decrease?

_____ %

Part B: Explain how you found your answer.

Part C: By what percent does the price need to increase in order to return to its original value of \$250,000?

_____ %

Part D: Explain how you found your answer.

Scoring Rubric

Points	Description
4	<p>The response achieves the following:</p> <ul style="list-style-type: none"> • The response demonstrates a complete understanding of using proportional relationships to solve multi-step percent problems. • Give 4 points for four parts answered correctly. <ul style="list-style-type: none"> • Response is correct and complete. • Response shows application of a reasonable and relevant strategy. • Mathematical ideas are expressed coherently through a clear, complete, logical, and fully developed response using words, calculations, and/or symbols as appropriate.
3	<p>The response achieves the following:</p> <ul style="list-style-type: none"> • The response demonstrates a nearly complete understanding of using proportional relationships to solve multi-step percent problems. • Give 3 points for three parts answered correctly. <ul style="list-style-type: none"> • Response is mostly correct but contains either a computation error or an unclear or incomplete explanation. • Response shows application of a relevant strategy, though it may be only partially applied or it may remain unexplained. • Mathematical ideas are expressed only partially using words, calculations, and/or symbols as appropriate.
2	<p>The response achieves the following:</p> <ul style="list-style-type: none"> • The response demonstrates a partial understanding of using proportional relationships to solve multi-step percent problems. • Give 2 points for two parts answered correctly. <ul style="list-style-type: none"> • Response is only partially correct. • Response shows application of a relevant strategy, though it may be only partially applied or remain unexplained. • Mathematical ideas are expressed only partially using words, calculations, and/or symbols as appropriate.
1	<p>The response achieves the following:</p> <ul style="list-style-type: none"> • The response demonstrates a minimal understanding of using proportional relationships to solve multi-step percent problems. • Give 1 point for one part answered correctly. <ul style="list-style-type: none"> • Response is only partially correct. • Response shows incomplete or inaccurate application of a relevant strategy. • Mathematical ideas are expressed only partially using words, calculations, and/or symbols as appropriate.
0	<p>The response achieves the following:</p> <ul style="list-style-type: none"> • The response demonstrates limited to no understanding of using proportional relationships to solve multi-step percent problems. <ul style="list-style-type: none"> • Response is incorrect. • Response shows no application of a strategy. • Mathematical ideas cannot be interpreted or lack sufficient evidence to support even a limited understanding.

Exemplar Response

Points Awarded	Sample Response
4	Part A: 16 Part B: I subtracted the new price from the original price and divided the difference by the original price. Then I multiplied the decimal product by 100 and removed the negative sign to write the percent decrease. Part C: approximately 19 Part D: I divided the difference in the two prices by the new price. Then I multiplied the decimal product by 100 to write the percent increase.
3	The student correctly answers three out of the four parts.
2	The student correctly answers two out of the four parts.
1	The student correctly answers one of the four parts.
0	<i>Response is irrelevant, inappropriate, or not provided.</i>

MATHEMATICS CONTENT DESCRIPTION AND ADDITIONAL SAMPLE ITEMS

In this section, you will find information about what to study in order to prepare for the Grade 7 Mathematics EOG assessment. This includes key terms and important vocabulary words. This section also contains practice questions, with an explanation of the correct answers, and activities that you can do on your own or with your classmates or family to prepare for the test.

All example and sample items contained in this guide are the property of the Georgia Department of Education.

CONTENT DESCRIPTION

- Apply and extend understanding of multiplication and division
- Divide fractions by fractions
- Compute fluently with multi-digit numbers and rational numbers
- Find common factors and multiples
- Apply and extend understandings of algebraic expressions
- Reason and solve one-variable equations and inequalities
- Analyze quantitative relationships between dependent and independent variables
- Understand ratio, area, surface area, and volume
- Develop understanding of statistical variability
- Summarize and describe distributions

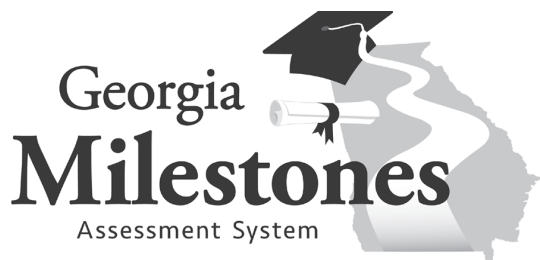

Mathematics Formula Sheet

You can find mathematics formula sheets on the Georgia Milestones webpage at <http://www.gadoe.org/Curriculum-Instruction-and-Assessment/Assessment/Pages/Georgia-Milestones-Assessment-System.aspx>.

Look under “EOG Resources.”

Unit 1: Operations with Rational Numbers

In this unit, you will work with rational numbers, use a number line to add and subtract rational numbers, and learn about absolute value and additive and multiplicative inverses. You will convert rational numbers to decimals using long division. You will use the four operations to solve problems with rational numbers.

KEY TERMS

Rational number: A number that can be made by dividing two **integers** or whole numbers. Rational numbers can be displayed as a point on a number line or coordinate plane. (NS.1)

Add and **subtract** rational numbers by representing the problem on a **number line** or utilizing colored counters. (NS.1)

Addition of rational numbers is finding the location of a sum. To complete this process, plot the first addend on the number line. Then, move the distance, or absolute value, of the second addend. The sign of the addend will determine which direction to move. If the number has a negative sign, move towards the negative numbers. For example, $3 + -4 = -1$ by starting at 3 and moving a distance of 4 in a negative direction. (NS.1b)

Absolute value: The distance between the given number and zero on a number line. For example, $|-5| = 5$. (NS.1b, NS.1c)

Opposite numbers: Two numbers that have the same absolute value. (NS.1)

Subtraction of rational numbers can also be represented as adding the **additive inverse** of the number. For example, $4 - 8$ can also be represented as $4 + (-8)$. (NS.1c)

Additive inverse: Two numbers that when added have a sum of zero. (NS.1c)

Use the **properties of operations** to **multiply** and **divide** rational numbers. Integers can be divided, as long as the divisor is not equal to 1. (NS.2)

Rules for multiplying signed numbers specify that two positive numbers or two negative numbers that are multiplied will have a positive product. The product of one positive number and one negative number will be negative. (NS.2a)

Multiplicative inverse: Two numbers that when multiplied have a product of 1.

A rational number can be converted to a **decimal** using **long division**. A rational number will be represented by a repeating decimal or a terminating decimal. (NS.2d)

Repeating decimal: A decimal number with a digit or groups of digits that repeats. The decimal continues without an end. (NS.2d)

Terminating decimal: A decimal number that has a specific amount of digits, a decimal number with an end. (NS.2d)

Use the **four operations** to solve problems with rational numbers. These problems may represent real-world situations or be mathematical. (NS.3)

Important Tips

 A negative number represents the **opposite** location on the number line as a positive number. For example, -2 is the opposite of 2.

 The opposite of the opposite of a number is the number itself. For example, $-(-2)$ is equal to 2.

Sample Items 1–4**Item 1**

John and Kamira are playing a game. John's score (J) and Kamira's score (K) after round 1 are shown on the number line.

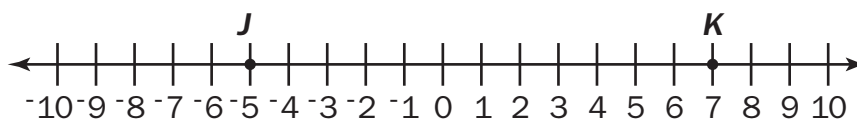

The score recorded at the end of the first round is 2. What could this score represent?

- A. The sum of John's score and Kamira's score.
- B. The difference between John's score and Kamira's score.
- C. The absolute value of the difference of John's score and Kamira's score.
- D. The sum of the absolute value of John's score and the absolute value of Kamira's score.

Item 2

What is the value of $4.2(46 - 65)$?

- A. -798
- B. -79.8
- C. 79.8
- D. 798

Item 3

What is the product?

$$-8(7 - 3.2)$$

- A. -59.2
- B. -30.4
- C. 30.4
- D. 52.8

Item 4

During one week, Sheila made several changes to her bank account. She made four withdrawals of \$40 each from an ATM. She also used her check card for a \$156 purchase. Then she deposited her paycheck of \$375.

By how much did the amount in her bank account change during that week?

- A. \$59 increase
- B. \$59 decrease
- C. \$691 increase
- D. \$691 decrease

Unit 2: Expressions and Equations

In this unit, you will use properties of operations to add, subtract, or rewrite linear expressions with rational coefficients in different forms. You will use estimation and variables to represent unknown numbers. You will work with inequalities and use a number line to graph solutions to an inequality. You will work with variables to solve equations.

KEY TERMS

Use **Properties of Operations** to **add, subtract**, or rewrite linear expressions with rational **coefficients** in different forms.

- **Distributive property** multiplies a factor that is outside of a set of parentheses with each addend within the parentheses to solve.
- **Commutative property** allows for addends in an addition equation or factors in a multiplication equation to be moved or placed in a different order while solving.
- **Associative property** allows for addends in addition equations or factors in multiplication equations to be grouped together into different pairs while solving.
- **Identity property** allows for 0 to be added or 1 to be multiplied by any number and the number remains the same.
- **Inverse property** allows a number to be added to the opposite number for a sum of zero. Also, a number multiplied by the reciprocal fraction has a product of 1. (EE.1)

Coefficient: A number multiplied by a variable. (EE.1)

Expressions can be written in different forms while representing the same value. Use the information provided in the problem to determine the most beneficial form to use such as written or numerical. (EE.2) Rational numbers can be written as **whole numbers, fractions, decimals, or percents** and be changed between forms depending on the problem being solved. (EE.3)

Estimation can be used to arrive at an approximate solution to a problem. When solving using strategies based on the properties of operations, compare the solution to the estimate. Use this comparison to determine if the solution to the problem is **reasonable**. (EE.3)

A **variable** in an equation or inequality represents an **unknown number** or a number in a given set of numbers. (EE.4)

Equation: A grouping of numbers, variables, and operations with an **equal sign**. The solution to an equation is a specific number that makes the equation true. (EE.4a)





Algebraic solution: Solve a problem by using the relationship between numbers including variables, setting up equations, and utilizing inverse relationships. (EE.4a)

Arithmetic solution: Solve a problem using the four operations on the given numbers. (EE.4a)

Inequality: A grouping of numbers, variables, and operations with an **inequality symbol** such as $<$, $>$, \leq , and \geq . The solution for an inequality is a set of numbers or multiple numbers that make the inequality true. (EE.4b)

Use a **number line** to **graph** the solutions to an inequality. (EE.4b)

Important Tips

-  An equal sign ($=$) represents that the two sides of the equation have the same value.
-  Variables are used to represent unknown numbers in an equation. A specific letter can be used to represent several different numbers in different equations.
-  The coefficient relates to the variable it is paired with. The value of $2n + 3$ is $n + n + 3$ and is determined based on the value of n . If $n = 5$, then $2n + 3$ has a value of $10 + 3$.
-  A variable listed alone is the same as having a coefficient of 1. For example, $3x - x$ is the same as $3x - 1x$ for a total of $2x$.

Sample Items 5–8**Item 5**

Consider the expression $6r - r + 8(15 - r) + 23 - 6$.

Part A: Is $-3r + 137$ equivalent to the given expression?

Part B: Explain how you determined whether the expressions are or are not equivalent.

<hr/> <hr/>

Item 6

Which expression is equivalent to $-7(y - 2)$?

- A. $-7y - 2$
- B. $-7y + 2$
- C. $-7y - 14$
- D. $-7y + 14$

Item 7

Julie works Sunday, Monday, and Wednesday for 10 hours each day. On Tuesday, Thursday, and Friday, she works 7 hours each day. She does not work on Saturday. Her weekly total earnings are \$612.

Part A: What is her hourly rate of pay?

\$ _____

Part B: Julie's manager proposes a new pay rate. The manager says Julie can get paid twice her hourly rate for working any hours over 8 in a day. What would be her weekly earnings using this method of payment? Explain how you found her total earnings using this method.

\$ _____

Part C: Julie thinks she can earn more money if she is paid $1\frac{1}{2}$ times her hourly rate for any hours over 40 in her weekly total. Which method of payment, Julie's or her manager's, would give Julie higher weekly earnings? Explain your reasoning.

Item 8

The sum of a number, n , and 8 is multiplied by -4 , and the result is -12 .

What is the number?

- A. $n = -5$
- B. $n = 1$
- C. $n = 5$
- D. $n = 11$

Unit 3: Ratios and Proportional Relationships

In this unit, you will use ratios and proportions with fractions, decimals, and percents. You will set up proportions and create scale drawings using scale factors.

KEY TERMS

Use given information, including a ratio of fractional measurements, to determine the unit rate. For example, the ratio $\frac{1}{2}$ feet in $\frac{1}{6}$ seconds has a unit rate of $\frac{1/2}{1/6}$ or 3 feet per second. (RP.1)

Ratio: Describes the relationship between two quantities and can be written as a **fraction, decimal, or percent**. (RP.1)

Unit rate: A ratio that has a number related to 1. For example, there is a ratio of red cars to blue cars of 2 to 1 or $\frac{2}{1}$. (RP.1)

Proportion: An equation that shows two ratios as being equivalent. (RP.2)

A proportional relationship will change by the same value over time. This value, the **constant of proportionality**, is represented by the value of the ratio (k) between y and x as $y = kx$. (RP.2)

A proportional relationship is identified using a **graph, table, or equation**. A graph of a proportional relationship will show a straight line that extends through the origin (0, 0). It can also be represented in an equation that relates two numbers or variables with the unit rate of change. For example, $y = 3x$ shows that the value of y is proportional to the value of x using the unit rate of 3 to 1. (RP.2)

Solve **ratio** and **percent** problems using proportional relationships including interest rates, tax, and percent increase or decrease. For example, a tree height increased from 100 inches to 120 inches. The percent of increase is $\frac{20}{100}$ or 20%. (RP.3)

Percent: A part-to-whole ratio that has a number related to 100. It can be written as a fraction with the denominator of 100 or using the symbol %. (RP.3)

Scale drawings: A drawing or geometric figure can change size using a **scale factor**, or ratio between the sets of measurements. For example, a 4-inch line that is decreased by a scale factor of $\frac{1}{2}$ will be changed to 2 inches.

A scale factor can be used to increase or decrease the size of a geometric figure.

Important Tips

- ✍ The constant of proportionality is the unit rate.
- ✍ A ratio can be represented using fractions, decimals, or percents. These forms can be used interchangeably because the value of the ratio does not change, only the form that is used to write the value.

Sample Items 9–12

Item 9

The average rate of hair growth is 2.5 centimeters every 2 months.

At that rate, how many months will it take to grow 22.5 centimeters of hair?

- A. 9 months
- B. $11\frac{1}{4}$ months
- C. 18 months
- D. $28\frac{1}{8}$ months

Item 10

Consider the graph.

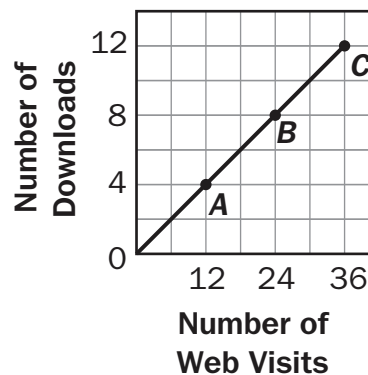

What does point A represent on this graph?

- A. When there are 12 web visits, there are 4 downloads.
- B. When there are 12 downloads, there are 4 web visits.
- C. As the number of web visits increases by 12, the number of downloads decreases by 4.
- D. As the number of web visits decreases by 12, the number of downloads increases by 4.

Item 11

During cooking, chicken loses 10% of its weight due to water loss. In order to obtain 1,170 grams of cooked chicken, how many grams of uncooked chicken must be used?

- A. 1,053 grams
- B. 1,287 grams
- C. 1,300 grams
- D. 1,340 grams

Item 12

A satellite is 18 meters wide. A model of it was built with a scale of 1 centimeter : 3 meters. How wide is the model?

- A. 6 meters
- B. 6 centimeters
- C. 54 meters
- D. 54 centimeters

Unit 4: Geometry

In this unit, you will work on geometry. You will use rulers and protractors to draw and measure geometric shapes, and in particular, angles, parallel lines, perpendicular lines, number of sides, length of sides, and the vertex. You will describe plane shapes and two- and three-dimensional figures. You will study circles, angles, area, surface area, and volume.

KEY TERMS

Use **rulers** and **protractors** as tools to draw geometric shapes given specific conditions including:

- **Angles:** The measure of the portion of a circle within two rays.
- **Parallel lines:** Two lines that are always an equal distance apart.
- **Perpendicular lines:** Two lines that intersect at a 90° angle.
- **Number of sides:** How many lines are used to create the figure.
- **Length of sides:** Measurement of the length of each line.
- **Vertex:** The point where two lines of the figure meet. (G.2)

Describe the faces of a **three-dimensional** figure by slicing the figure into **plane shapes** and describing the **attributes** of the **two-dimensional** face. (G.3)

Circle:

- **Area:** The square units needed to cover a circle can be found by multiplying the square of the **radius** by **pi**. $A = \pi r^2$
- **Circumference:** The distance around the circle, found by multiplying the **diameter** by **pi**. $C = \pi d$ (G.4)

Find the measure of an unknown angle using:

- **Supplementary angles:** Two angles that have a sum of 180° .
- **Complimentary angles:** Two angles that have a sum of 90° .
- **Vertical angles:** Nonadjacent angles that are formed by intersecting lines, opposite angles.
- **Adjacent angles:** Two angles that share 1 side and 1 vertex. (G.5)

Find the **area**, **surface area**, and **volume** of two-dimensional and three-dimensional figures by decomposing the figures into triangles, quadrilaterals, polygons, cubes, and right rectangular prisms. (G.6)

Area: The number of square units used to cover a two-dimensional figure without gaps or overlaps.

- Rectangle: Multiply the length and width of the rectangle. $A = lw$
- Triangle: Multiply the height and base of the triangle, then divide by 2. $A = \frac{1}{2}bh$ (G.6)

Surface area: The total area of each face of a three-dimensional figure. (G.6)

Volume: The amount of space the shape takes up in three dimensions: length, width, and height. A solid figure can be packed with equally sized cubes without gaps or overlaps. (G.6)

The volume of a right rectangular prism can be determined using two formulas.

- lwh multiplies the **length**, **width**, and **height** of the figure to find the cubic units of volume.
- Bh finds the **area of the base** using the width and length, and then multiplies it by the **height** of the figure to find the cubic units of volume. (G.6)

Important Tips

- ✍ In triangles the height must be measured from the highest point and be perpendicular to the base.
- ✍ The radius is half of the diameter, or half the distance across a circle.
- ✍ The ratio of the circumference to the diameter is pi, which can be represented in equations as 3.14.

Sample Items 13–16

Item 13

A bicycle training wheel has a radius of 3 inches. The bicycle wheel has a radius of 10 inches. Approximately how much smaller, in square inches, is the area of the training wheel than the area of the regular wheel?

- A. 21.98 in²
- B. 153.86 in²
- C. 285.74 in²
- D. 1,142.96 in²

Item 14

Lequan is giving a book as a gift. She will put the book in a box and wrap it. Both the book and box are shaped like rectangular prisms with the dimensions shown in the diagrams.

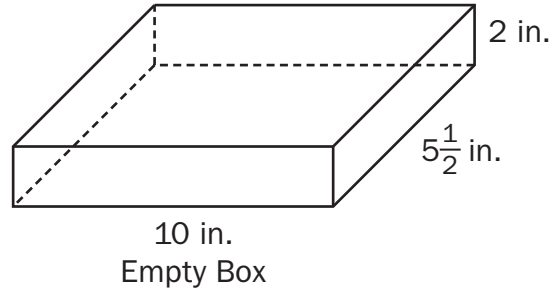
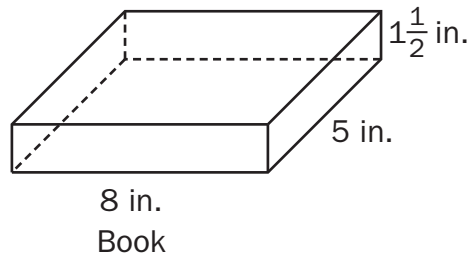

Part A: How much empty space will be in the box after Lequan puts the book inside it?

_____ cubic inches

Part B: What is the minimum amount of wrapping paper needed to completely cover the outside of the box?

_____ square inches

Item 15

Consider the diagram of supplementary angles.

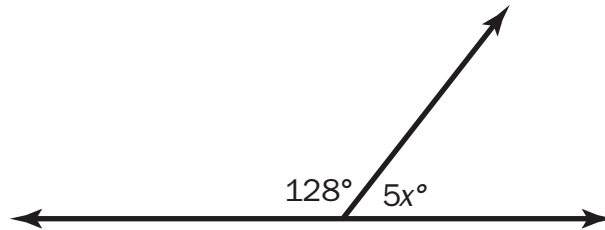

What is the value of x ?

- A. 10.4
- B. 52
- C. 61.6
- D. 92

Item 16

Consider the figure composed of two rectangular prisms.

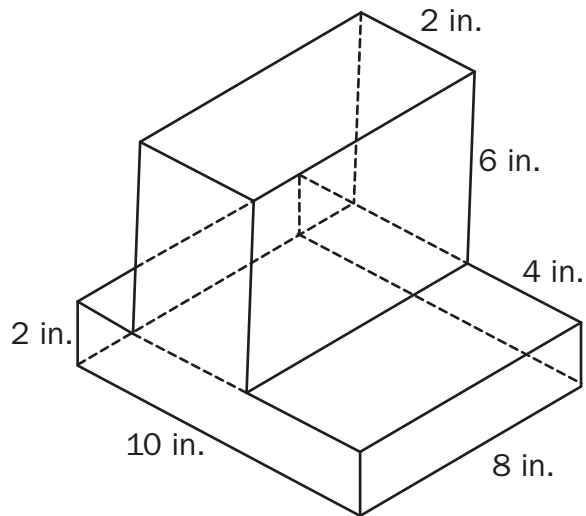

What is the volume of this figure?

- A. 32 in^3
- B. 256 in^3
- C. 416 in^3
- D. $7,680 \text{ in}^3$

Unit 5: Inferences

In this unit, you will use statistical information, gather samples, and make inferences. Samples may be random sampling or representative samples. You will use data and construct dot plots, box plots, and histograms. You will learn about distribution of data using the mean, median, and absolute deviation.

KEY TERMS

Statistical information on a large population can be gathered using a sample of the **population**. (SP.1)

Representative sample: A part of the population used to gather information, representing the entire population. (SP.1)

Random sampling: Allows individuals from each group within a population to be represented in the sample set. (SP.1)

Use the **data** collected from a sampling of the population to make **inferences** on the entire population. (SP.2)

Inference: A conclusion, estimate, or prediction based on data. (SP.2)

Assess the distribution of two sets of numerical data visually using **dot plots**, **box plots**, or **histograms**. For example, the median weight of watermelons is 5 pounds more than the median weight of apples. (SP.3)

Distribution of data can be described using:

- **Center:** The one number that summarizes data by giving the middle or center value. This can be measured using the **mean** if the data are symmetrical or **median** if the data are skewed.
- **Interquartile range:** The range, or difference, in values of the first and third quartiles. (SP.3)
- **Mean:** The “average” or “fair share” value for the data. The mean is also the balance point of the corresponding data distribution. (SP.4)
- **Median:** The value for which half the numbers are larger and half are smaller. If there are two middle numbers, the median is the arithmetic mean of the two middle numbers. (SP.4)
- **Range:** A measure of spread for a set of data. To find the range, subtract the smallest value from the largest value in a set of data. (SP.4)
- **Skewed data:** When a set of data is not symmetrical it can be skewed, meaning it tends to have a long tail on the left or right side. (SP.3)
- **Spread:** The one number that summarizes the variation in the data. This can be measured by the **range** or **interquartile range**.
- **Overall shape:** The **frequency** of data and any data that are **skewed** to the left or right. (SP.3)

Use the distribution of numerical data on two different populations to make **inferences that compare** the two populations. (SP.4)

Important Tip

- ✍ A sample of the population must represent all groups within that population in order for generalizations on the population to be made. For example, a sample of populations of dogs must include individuals from many different breeds. The data would be invalid if the sample only included larger breed dogs, such as Labradors.

Sample Items 17–20**Item 17**

A gym teacher at Jackson High School wants the school to have a new team sport: soccer, lacrosse, or rugby. She will take a survey to determine which of those sports most students prefer. Which population would provide a random sampling for the gym teacher to use?

- A. all students at the school who are sixteen years old
- B. all students who buy lunch at the school on Friday
- C. half of the students who play on team sports at the school
- D. every third student arriving at school

Item 18

Listed below are the quiz scores for randomly selected students in two seventh-grade classes.

Class A: 99, 75, 84, 70, 86, 80

Class B: 85, 83, 87, 90, 85, 82

Part A: Based on the samples, which class generally has higher quiz scores?

Part B: Use measures of center and/or variability to justify your answer.

<hr/> <hr/>

Item 19

Consider the two box plots.

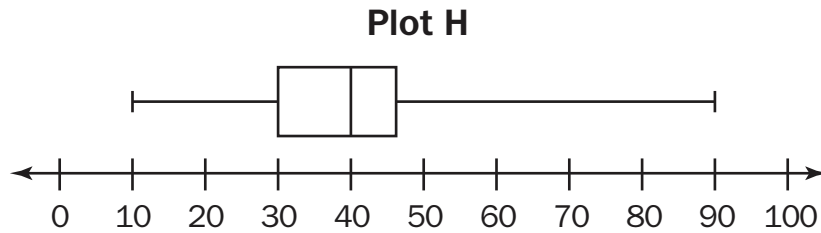
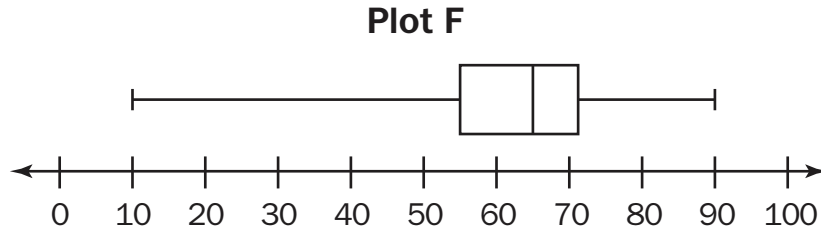

Which statement is TRUE?

- A. Plot F has a greater range than Plot H.
- B. Each plot has more than 25% of the data greater than 50.
- C. The median of Plot F is greater than the median of Plot H.
- D. The spread between the upper and lower quartiles on both graphs is 10.

Item 20

Use the dot plots to answer the questions.

Plot A

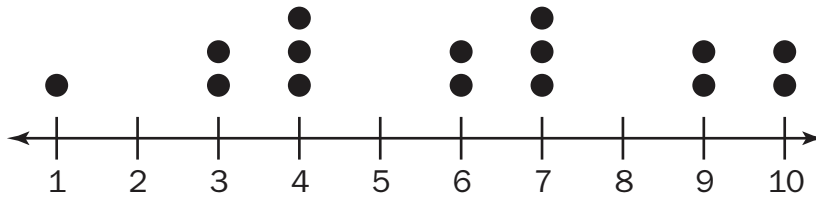

Plot B

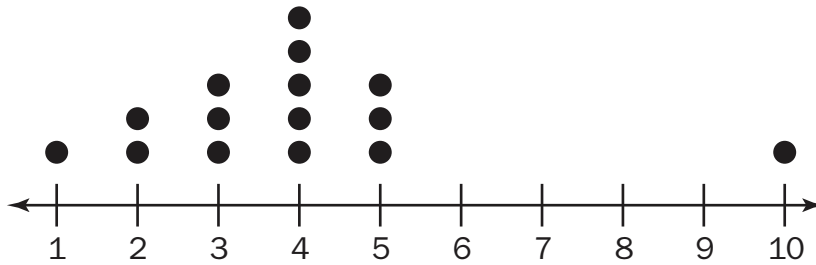

Part A: What is the difference between the medians of Plot A and Plot B? Explain how you found your answer.

Part B: Which plot has the greater mean? Explain how you found your answer.

Unit 6: Probability

In this unit, you will work with probability and frequency models. You will find the probability of compound and mutually exclusive events. You will work with simulations and tree diagrams.

KEY TERMS

Probability: The chance that an event will occur expressed as a number between 0 and 1. A small number represents a small likelihood that an event will occur. (SP.5)

Estimate the **probability** of an event occurring by collecting **data** on the frequency of the event occurring. (SP.6)

Probability model: Includes the probability for each possible individual outcome, showing the total probability of all outcomes is 1. (SP.7)

Experimental probability: the **probability** of an event occurring when an experiment was conducted. (SP.7)

Theoretical probability: the likeliness of an event happening based on all the possible outcomes. (SP.7)

Compare the **frequency** of events from a **model** with actual observed occurrences. Explain why the information from the model and actual events are similar or different. (SP.7)

The probability of a **compound event** occurring is found by combining the probability of each **mutually exclusive** event. (SP.8)

Compound events: A combination of more than one simple event. (SP.8)



Sample space: A set of all possible outcomes for an event or combination of events. (SP.8)

Represent the **sample space** of a **compound event** using models such as lists, tables, **simulations**, and **tree diagrams**. (SP.8)

Tree diagram: A visual model that sequentially lists all possible outcomes for an event. (SP.8)

Simulation: A model used to answer questions where chance is involved; it is used to generate frequencies for compound events. (SP.8c)

Important Tips

-  An event with a probability of $\frac{1}{2}$ has an event that is neither likely nor unlikely. It has an equal chance of occurring or not occurring.
-  Chance or probability is not affected by the outcome of a previous event.
-  The sum of the probability for each outcome in a situation will equal 1. For example, a coin flipped has a $\frac{1}{2}$ probability of landing heads up or a $\frac{1}{2}$ probability of landing tails up.

Sample Items 21–24**Item 21**

A bag contains 14 blue marbles and 14 purple marbles.

What is the likelihood of randomly drawing a purple marble?

- A. certain
- B. likely
- C. neither unlikely nor likely
- D. not likely

Item 22

A number cube with faces numbered 1 to 6 is rolled 15 times.

In theory, how many times would you expect to roll a number less than 5?

- A. 2.5
- B. 5
- C. 10
- D. 12.5

Item 23

The table shows the results of randomly selecting colored marbles from a bag 40 times. The marble was returned to the bag after each selection.

	Purple	Green	Blue	White	Pink
Number of Times Selected	16	8	6	9	1

Based on these results, what is the expected probability of randomly selecting a green marble from the bag in one attempt?

- A. 0.125
- B. 0.20
- C. 0.80
- D. 1.0

Item 24

The six sides of a number cube are labeled 1, 2, 3, 4, 5, and 6. You flip a coin and roll the number cube. In theory, what is the probability that the coin lands on heads and you roll a number greater than 4?

- A. $\frac{1}{12}$
- B. $\frac{1}{6}$
- C. $\frac{1}{3}$
- D. $\frac{1}{2}$

MATHEMATICS ADDITIONAL SAMPLE ITEM KEYS

Item	Standard/ Element	DOK Level	Correct Answer	Explanation
1	MGSE7.NS.1b	1	C	The correct answer is choice (A) The sum of John's score and Kamira's score. The number 2 was correctly identified as the sum of their scores. Choice (B) is incorrect because the incorrect sign was used for John's score before it was subtracted from Kamira's score. Choice (C) is incorrect because the scores were added together using the opposite sign. Choice (D) is incorrect because the scores were added before taking the absolute value.
2	MGSE7.NS.2a	1	B	The correct answer is choice (B) -79.8 because the difference, -19 , is multiplied by 4.2 . Choice (A) is incorrect because the decimal was not used when multiplying. Choice (C) is incorrect because the integers in the parentheses were reversed, resulting in $+19$ multiplied by 4.2 . Choice (D) is incorrect because the integers in the parentheses were reversed and the decimal was not used when multiplying.
3	MGSE7.NS.2a	1	B	The correct answer is choice (B) -30.4 . Use the Distributive Property: $-8(7) + 8(3.2) = -30.4$ or the order of operations: $-8(3.8) = -30.4$. Choice (A) ignores the parentheses: $-8(7) - 3.2$. Choice (C) is incorrect because the product of a positive and negative is negative. Choice (D) ignores the parentheses and the rules for multiplying signed numbers.
4	MGSE7.NS.3	2	A	The correct answer is choice (A) \$59 increase. The integer rules for multiplying, adding, and subtracting were performed accurately. Choice (B) is incorrect because the amounts of the withdrawals and the purchase were added together as positive numbers and subtracted from the amount of the paycheck deposit, which was treated as a negative. Choice (C) is incorrect because the operations were performed with all the numbers being positive. Choice (D) is incorrect because the operations were performed with all negative numbers.
5	MCC7EE1	2	N/A	See scoring rubric and sample response beginning on page 107.

Item	Standard/ Element	DOK Level	Correct Answer	Explanation
6	MGSE7.EE.1	2	D	The correct answer is choice (D) $-7y + 14$ because the Distributive Property and the rules for multiplying integers are correctly used. Choice (A) is incorrect because the Distributive Property and the rules for multiplying integers were not used. Choice (B) is incorrect because the Distributive Property was not used, even though the rules for multiplying integers were. Choice (C) is incorrect because the rules for multiplying integers were not used, but the Distributive Property was used.
7	MGSE7.EE.3	3	N/A	See scoring rubric and sample response beginning on page 109.
8	MGSE7.EE.4a	2	A	The correct answer is choice (A) $n = -5$ because the equation was correctly set up as $-4(n + 8) = -12$, and both the Distributive Property and the rules for multiplying integers were correctly used to solve. Choice (B) is incorrect because the -4 was not distributed to the 8 and the sign of 8 was negative, which resulted in an incorrect equation being solved correctly. Choice (C) is incorrect because the -4 was not distributed to the 8, which resulted in an incorrect equation being solved correctly. Choice (D) is incorrect because the sign of 8 was a negative, which resulted in an incorrect equation being solved correctly.
9	MGSE7.RP.3	1	C	The correct answer is choice (C) 18 months because the proportion $\frac{2.5 \text{ cm}}{2 \text{ mo}} = \frac{22.5 \text{ cm}}{x \text{ mo}}$ was set up and solved correctly. Choice (A) is incorrect because it is the result of dividing 22.5 by 2.5. Choice (B) is incorrect because it is the result of dividing 22.5 by 2. Choice (D) is incorrect because it is the result of setting up and solving the incorrect proportion $\frac{2 \text{ mo}}{2.5 \text{ cm}} = \frac{22.5 \text{ cm}}{x \text{ mo}}$.

Item	Standard/ Element	DOK Level	Correct Answer	Explanation
10	MGSE7.RP.2d	2	A	The correct answer is choice (A) When there are 12 web visits, there are 4 downloads. Each point (x, y) on the graph represents (<i>number of web visits, number of downloads</i>). So the point (12, 4) represents the fact that when there are 12 web visits, there are 4 downloads. Choice (B) is incorrect because it reverses the meaning of the coordinates. Choices (C) and (D) are both incorrect because a single point does not represent the slope/rate of change, and both values are increasing: As the number of web visits increases, the number of downloads increases.
11	MGSE7.RP.3	2	C	The correct answer is choice (C) 1,300 grams. It is found by dividing 1,170 by 0.90. Choice (A) is incorrect because it is the result of multiplying 0.9 and 1,170. Choice (B) is incorrect because it is the result of multiplying 1.1 and 1,170. Choice (D) is incorrect because it is the result of adding 10% of 1,170 to 1,170.
12	MGSE7.G.1	2	B	The correct answer is choice (B) 6 centimeters because the proportion $\frac{1 \text{ cm}}{3 \text{ m}} = \frac{x \text{ cm}}{18 \text{ m}}$ was set up and solved correctly. Choice (A) is incorrect because the wrong unit label is used. Choice (C) is incorrect because the scale was not applied correctly, and the wrong unit label is used. Choice (D) is incorrect because the scale was not applied correctly.
13	MGSE7.G.4	2	C	The correct answer is choice (C) 285.74 in ² because the area of the wheel is 314 square inches and the area of the training wheel is 28.26 square inches, resulting in a difference of 285.74 square inches. Choice (A) is incorrect because the radius of each wheel was not squared in the area formula. Choice (B) is incorrect because the difference of the radii was computed first and then substituted into the area formula. Choice (D) is incorrect because the diameter of each wheel was used and substituted into the formula.
14	MGSE7.G.6	3	N/A	See scoring rubric and sample response on page 112.

Item	Standard/ Element	DOK Level	Correct Answer	Explanation
15	MGSE7.G.5	2	A	The correct answer is choice (A) 10.4 because $(180 - 128) \div 5 = x$. Choice (B) is incorrect because $(180 - 128)$ was not divided by 5 to find x . Choice (C) is incorrect because the angle measure of 128 was added to 180 and then divided by 5. Choice (D) is incorrect because it is the solution to $128 - (180 \div 5)$.
16	MGSE7.G.6	2	B	The correct answer is choice (B) 256 in^3 because the shape was divided into two rectangular prisms and the volume of each was added together. Choice (A) is incorrect because all the given measurements were added together. Choice (C) is incorrect because the wrong dimensions $(10 \cdot 8 \cdot 4)$ were used to find the base volume. Choice (D) is incorrect because all the given dimensions were multiplied together.
17	MGSE7.SP.1	2	D	The correct answer is choice (D) every third student arriving at school. This correct choice will result in the most random sample. Choice (A) is incorrect because it excludes most students in several grades. Choice (B) is incorrect because it is not a random sample—all students in the population do not have an equal chance of being selected. Choice (C) is incorrect because it is not a random sample—it excludes students who do not play on teams.
18	MGSE7.SP.4	2	N/A	See scoring rubric and sample response on page 113.
19	MGSE7.SP.3	2	C	The correct answer is choice (C) The median of Plot F is greater than the median of Plot H. The median of Plot F is 65, which is greater than the median of Plot H, which is 40. Choice (A) is incorrect because both plots have a range of 80. Choice (B) is incorrect because Plot H has less than 25% of its data greater than 50. Choice (D) is incorrect because the lower quartile of Plot F is 55 and the upper quartile is about 70, which is a spread of 15. Plot H has a lower quartile of 30 and an upper quartile of about 45, which is a spread of 15.
20	MGSE7.SP.4	2	N/A	See scoring rubric and sample response beginning on page 114.

Item	Standard/ Element	DOK Level	Correct Answer	Explanation
21	MGSE7.SP.5	2	C	The correct answer is choice (C) neither unlikely nor likely. The number of each color of marbles is equal, so each color is equally likely to be chosen. Choice (A) is incorrect because there is more than one color of marbles. Choice (B) is incorrect because the number of purple marbles is not greater than the number of blue marbles. Choice (D) is incorrect because the number of purple marbles is not less than the number of blue marbles.
22	MGSE7.SP.6	2	C	The correct answer is choice (C) 10. For each roll, there is a 4 out of 6 chance of rolling a number less than 5, and $\frac{4}{6} \cdot 15 = \frac{60}{6} = 10$. Choice (A) is incorrect because it includes the chances of rolling a number more than 5. Choice (B) is incorrect because it includes rolling a 5 or more. Choice (D) is incorrect because it includes rolling a 5 or less.
23	MGSE7.SP.7b	1	B	The correct answer is choice (B) 0.20 because there are 8 green marbles, and $8 \div 40 = 0.20$. Choice (A) is incorrect because it is the probability of picking 1 green marble out of 8 total selections. Choice (C) is incorrect because it is the probability that the marble is not green. Choice (D) is incorrect because it is the probability that a marble of any color will be selected.
24	MGSE7.SP.8a	2	B	The correct answer is choice (B) $\frac{1}{6}$ because there are 12 possible outcomes: {H1, H2, H3, H4, H5, H6, T1, T2, T3, T4, T5, T6} and 2 of those outcomes are heads and greater than 4: {T5, T6}. Therefore the probability is $\frac{2}{12} = \frac{1}{6}$. Choice (A) is incorrect because there are 2 ways to get heads and a number greater than 4, not 1 way. Choice (C) is incorrect because it is the probability of getting a number greater than 4. Choice (D) is incorrect because it includes H4 in the count of favorable outcomes; it is also the probability of getting heads.

MATHEMATICS SAMPLE SCORING RUBRICS AND EXEMPLAR RESPONSES

Item 5

Scoring Rubric

Points	Description
2	<p>The response achieves the following:</p> <ul style="list-style-type: none"> • Response demonstrates a complete understanding of applying properties of operations to simplify expressions with rational coefficients. • Give 2 points for the correct answer and explanation. <ul style="list-style-type: none"> • Response is correct and complete. • Response shows application of a reasonable and relevant strategy. • Mathematical ideas are expressed coherently through a clear, complete, logical, and fully developed response using words, calculations, and/or symbols as appropriate.
1	<p>The response achieves the following:</p> <ul style="list-style-type: none"> • Response demonstrates a partial understanding of applying properties of operations to simplify expressions with rational coefficients. • Give 1 point for the correct answer but an incorrect explanation, or for an incorrect answer but a correct explanation of that incorrect answer. <ul style="list-style-type: none"> • Response is mostly correct but contains either a computation error or an unclear or incomplete explanation. • Response shows application of a relevant strategy, though it may be only partially applied or it may remain unexplained. • Mathematical ideas are expressed only partially using words, calculations, and/or symbols as appropriate.
0	<p>The response achieves the following:</p> <ul style="list-style-type: none"> • The response demonstrates limited to no understanding of applying properties of operations to simplify expressions with rational coefficients. <ul style="list-style-type: none"> • Response is incorrect. • Response shows no application of a strategy. • Mathematical ideas cannot be interpreted or lack sufficient evidence to support even a limited understanding.

Exemplar Response

Points Awarded	Sample Response
2	Part A: yes Part B: I combined like terms in the given expression. The result was the expression in Part A. I also substituted the same value for the variable into both expressions and it always resulted in the same answer.
1	Part A: yes Part B: The expressions are the same.
0	<i>Response is irrelevant, inappropriate, or not provided.</i>

Item 7

Scoring Rubric

Points	Description
4	<p>The response achieves the following:</p> <ul style="list-style-type: none"> • The response demonstrates a complete understanding of solving multi-step, real-life problems posed with rational numbers in any form. • Give 4 points for three parts answered correctly and explanations given. <ul style="list-style-type: none"> • Response is correct and complete. • Response shows application of a reasonable and relevant strategy. • Mathematical ideas are expressed coherently through a clear, complete, logical, and fully developed response using words, calculations, and/or symbols as appropriate.
3	<p>The response achieves the following:</p> <ul style="list-style-type: none"> • The response demonstrates a nearly complete understanding of solving multi-step, real-life problems posed with rational numbers in any form. • Give 3 points for three parts answered correctly for Parts A, B, and C but no explanation for Part B OR correct and complete Parts B and C based on a flawed answer for Part A. <ul style="list-style-type: none"> • Response is mostly correct but contains either a computation error or an unclear or incomplete explanation. • Response shows application of a relevant strategy, though it may be only partially applied or it may remain unexplained. • Mathematical ideas are expressed only partially using words, calculations, and/or symbols as appropriate.
2	<p>The response achieves the following:</p> <ul style="list-style-type: none"> • The response demonstrates a partial understanding of solving multi-step, real-life problems posed with rational numbers in any form. • Give 2 points for two parts answered correctly OR Parts A and B answered correctly but no explanation for Parts B and C OR Parts B and C answered correctly but not completely and based on a flawed answer in Part A. <ul style="list-style-type: none"> • Response is only partially correct. • Response shows application of a relevant strategy, though it may be only partially applied or remain unexplained. • Mathematical ideas are expressed only partially using words, calculations, and/or symbols as appropriate.

Points	Description
1	<p>The response achieves the following:</p> <ul style="list-style-type: none">• The response demonstrates a minimal understanding of solving multi-step, real-life problems posed with rational numbers in any form.• Give 1 point for one part answered correctly.<ul style="list-style-type: none">• Response is only partially correct.• Response shows incomplete or inaccurate application of a relevant strategy.• Mathematical ideas are expressed only partially using words, calculations, and/or symbols as appropriate.
0	<p>The response achieves the following:</p> <ul style="list-style-type: none">• The response demonstrates limited to no understanding of solving multi-step, real-life problems posed with rational numbers in any form.<ul style="list-style-type: none">• Response is incorrect.• Response shows no application of a strategy.• Mathematical ideas cannot be interpreted or lack sufficient evidence to support even a limited understanding.

Exemplar Response

Points Awarded	Sample Response
4	<p>Part A: 12 Part B: 684</p> <p>[Manager’s method] Julie works a total of 51 hours a week. On 3 days she works more than 8 hours. On each of those days, she works for 10 hours, which makes a total of 6 extra hours each week. Twice her hourly rate is 24, so she would earn 144 dollars extra each week. She would earn 12 per hour for the other 45 hours, for a total of 540 dollars. So her weekly total is the sum of 540 and 144, which is 684.</p> <p>Part C: Manager’s method. Since Julie works 51 hours a week, then she works 11 extra hours and would earn 18 dollars per hour for each of those extra hours, for a total of 198 dollars. She would earn 12 per hour for her regular 40 hours, for a total of 480. So her weekly total is the sum of 480 and 198, which is 678.</p>
3	The student correctly answers three out of the four parts.
2	The student correctly answers two out of the four parts.
1	The student correctly answers one of the four parts.
0	<i>Response is irrelevant, inappropriate, or not provided.</i>

Item 14

Scoring Rubric

Points	Description
2	<p>The response achieves the following:</p> <ul style="list-style-type: none"> • Response demonstrates a complete understanding of solving real-world problems involving volume and surface area of prisms. • Give 2 points for Part A AND Part B correct. <ul style="list-style-type: none"> • Response is correct and complete. • Response shows application of a reasonable and relevant strategy. • Mathematical ideas are expressed coherently through a clear, complete, logical, and fully developed response using words, calculations, and/or symbols as appropriate.
1	<p>The response achieves the following:</p> <ul style="list-style-type: none"> • Response demonstrates a partial understanding of solving real-world problems involving volume and surface area of prisms. • Give 1 point for Part A OR Part B correct. <ul style="list-style-type: none"> • Response is mostly correct but contains either a computation error or an unclear or incomplete explanation. • Response shows application of a relevant strategy, though it may be only partially applied or remain unexplained. • Mathematical ideas are expressed only partially using words, calculations, and/or symbols as appropriate.
0	<p>The response achieves the following:</p> <ul style="list-style-type: none"> • The response demonstrates limited to no understanding of solving real-world problems involving volume and surface area of prisms. <ul style="list-style-type: none"> • Response is incorrect. • Response shows no application of a strategy. • Mathematical ideas cannot be interpreted or lack sufficient evidence to support even a limited understanding.

Exemplar Response

Points Awarded	Sample Response
2	Part A: 50 Part B: 172
1	Part A: 50 Part B: No
0	<i>Response is irrelevant, inappropriate, or not provided.</i>

Item 18

Scoring Rubric

Points	Description
2	<p>The response achieves the following:</p> <ul style="list-style-type: none"> • Response demonstrates a complete understanding of comparing two populations using a measure of center or variability. • Give 2 points for the correct rate of change and the correct equation. <ul style="list-style-type: none"> • Response is correct and complete. • Response shows application of a reasonable and relevant strategy. • Mathematical ideas are expressed coherently through a clear, complete, logical, and fully developed response using words, calculations, and/or symbols as appropriate.
1	<p>The response achieves the following:</p> <ul style="list-style-type: none"> • Response demonstrates a partial understanding of comparing two populations using a measure of center or variability. • Give 1 point for Part A OR Part B correct, OR if Part A is correct but justification in Part B is only partially correct. <ul style="list-style-type: none"> • Response is mostly correct but contains either a computation error or an unclear or incomplete explanation. • Response shows application of a relevant strategy, though it may be only partially applied or remain unexplained. • Mathematical ideas are expressed only partially using words, calculations, and/or symbols as appropriate.
0	<p>The response achieves the following:</p> <ul style="list-style-type: none"> • The response demonstrates limited to no understanding of comparing two populations using a measure of center or variability. <ul style="list-style-type: none"> • Response is incorrect. • Response shows no application of a strategy. • Mathematical ideas cannot be interpreted or lack sufficient evidence to support even a limited understanding.

Exemplar Response

Points Awarded	Sample Response
2	<p>Part A: Class B Part B: Class B has a higher mean score and a smaller range than Class A. Therefore, in general, Class B has higher scores. <i>Or other valid explanation</i></p>
1	<p>Part A: Class B Part B: All Class B's scores are higher than Class A's scores.</p>
0	<p><i>Response is irrelevant, inappropriate, or not provided.</i></p>

Item 20

Scoring Rubric

Points	Description
2	<p>The response achieves the following:</p> <ul style="list-style-type: none"> • Response demonstrates a complete understanding of using measures of center to draw informal comparative inferences about two populations. • Give 2 points for the correct rate of change and the correct equation. <ul style="list-style-type: none"> • Response is correct and complete. • Response shows application of a reasonable and relevant strategy. • Mathematical ideas are expressed coherently through a clear, complete, logical, and fully developed response using words, calculations, and/or symbols as appropriate.
1	<p>The response achieves the following:</p> <ul style="list-style-type: none"> • Response demonstrates a partial understanding of using measures of center to draw informal comparative inferences about two populations. • Give 1 point for Part A OR Part B correct. <ul style="list-style-type: none"> • Response is mostly correct but contains either a computation error or an unclear or incomplete explanation. • Response shows application of a relevant strategy, though it may be only partially applied or it may remain unexplained. • Mathematical ideas are expressed only partially using words, calculations, and/or symbols as appropriate.
0	<p>The response achieves the following:</p> <ul style="list-style-type: none"> • The response demonstrates limited to no understanding of using measures of center to draw informal comparative inferences about two populations. <ul style="list-style-type: none"> • Response is incorrect. • Response shows no application of a strategy. • Mathematical ideas cannot be interpreted or lack sufficient evidence to support even a limited understanding.

Exemplar Response

Points Awarded	Sample Response
2	<p>Part A: The difference is 2. To find the median, arrange the data from least to greatest, and the middle number is the median. The median of Plot A is 6 and the median of Plot B is 4, so the difference is 2.</p> <p>AND</p> <p>Part B: Plot A has the greater mean. To find the mean for each plot, I divided the sum of its data values by its number of data values. Then I compared the two means.</p>
1	<p>Part A: The difference is 3. To find the median, arrange the data from least to greatest, and the middle number is the median. The median of Plot A is 9 and the median of Plot B is 6, so the difference is 3.</p> <p>OR</p> <p>Part B: Plot A has the greater mean. To find the mean for each plot, I divided the sum of its data values by its number of data values. Then I compared the two means.</p>
0	<p><i>Response is irrelevant, inappropriate, or not provided.</i></p>

SCIENCE

DESCRIPTION OF TEST FORMAT AND ORGANIZATION

The Grade 7 Science EOG assessment has a total of 75 selected-response (multiple-choice) items.

The test will be given in two sections.

- You may have up to 70 minutes per section to complete Sections 1 and 2.
- The total estimated testing time for the Grade 7 Science EOG assessment ranges from approximately 90 to 140 minutes.

CONTENT

The Grade 7 Science EOG assessment will measure the Grade 7 Science standards that are described at www.georgiastandards.org. The science items also relate to a Characteristics of Science standard. Because science consists of a way of thinking and investigating and includes a growing body of knowledge about the natural world, you will need to understand the **Characteristics of Science** standards and the **Content** standards for Science. The Characteristics of Science and Nature of Science standards can also be found at www.georgiastandards.org.

The content of the assessment covers standards that are reported under these domains:

- Cells, Human Body, and Genetics
- Evolution
- Interdependence of Life

ITEM TYPES

The science portion of the Grade 7 EOG assessment consists of selected-response (multiple-choice) items only.

SCIENCE DEPTH OF KNOWLEDGE EXAMPLE ITEMS

Example items that represent applicable DOK levels of the Science assessment are provided for you on the following pages. The items and explanations of what is expected of you to answer them will help you prepare for the test.

All example and sample items contained in this guide are the property of the Georgia Department of Education.

Example Item 1

DOK Level 1: This is a DOK level 1 item because the question requires the student to recall information concerning a known relationship between scientific quantities.

Science Grade 7 Domain: Cells, Human Body, and Genetics

Standard: S7L2. Students will describe the structure and function of cells, tissues, organs, and organ systems. c. Explain that cells are organized into tissues, tissues into organs, organs into systems, and systems into organisms.

Standard: S7S5a. Observe and explain how parts can be related to other parts in a system such as predator/prey relationships in a community/ecosystem.

Which of these correctly lists the four levels of organization for a multi-cellular organism in order, from smallest to largest?

- A. cells, tissues, organ systems, organs, organism
- B. cells, organs, organ systems, tissues, organism
- C. tissues, organs, organ systems, cells, organism
- D. cells, tissues, organs, organ systems, organism

Correct Answer: D

Explanation of Correct Answer: The correct answer is choice (D) cells, tissues, organs, organ systems, organism. The smallest unit of life is the cell. Specialized cells group together to form tissues. Tissues that work together to perform a specific activity form an organ. Groups of two or more organs combine to create an organ system. Organisms are made up of multiple organ systems. Choice (A) is incorrect because it puts “organ systems” before “organs.” Choice (B) is incorrect because “tissues” should be placed immediately after “cells,” not “organ systems.” Choice (C) is incorrect because although all the levels are present, they are not in the correct order.

Example Item 2

DOK Level 2: This is a DOK level 2 item because the question requires the student to apply learned information to abstract and real-life situations.

Science Grade 7 Domain: Evolution

Standard: S7L5. Students will examine the evolution of living organisms through inherited characteristics that promote survival of organisms and the survival of successive generations of their offspring. c. Trace evidence that the fossil record found in sedimentary rock provides evidence for the long history of changing life forms.

Standard: S7CS8c. As prevailing theories are challenged by new information, scientific knowledge may change.

Scientists find a fossil (Fossil A) in a deep layer of sedimentary rock. They determine that Fossil A is the remains of a species never seen before. A few years later, other scientists discover a similar fossil (Fossil B) in a layer of sedimentary rock closer to Earth's surface. Fossil A and Fossil B share some characteristics, but it is determined that they are not closely related and that Fossil B is a different species. One hundred years later, scientists discover another similar fossil (Fossil C) in a layer of sedimentary rock between those in which Fossils A and B were found. Upon examining all three fossils, scientists reach the conclusion that all three fossils represent the same species. They determine that Fossil B (found in the shallowest rock layer) evolved from Fossil C (found in an intermediary layer), which evolved from Fossil A (found in the deepest rock layer).

Which statement BEST describes this scenario?

- A. Very little can be learned about the evolution of a species by examining the fossil record.
- B. Early fossil researchers did not understand the information provided by the fossil record.
- C. The fossil record provides trace evidence for the long history of changing life forms.
- D. Theories about the fossil record do not change based on finding new evidence.

Correct Answer: C

Explanation of Correct Answer: The correct answer is choice (C) The fossil record provides trace evidence for the long history of changing life forms. Scientists have learned a lot about the evolution of living things by studying fossils and where they appear in sedimentary rock layers. Choice (A) is incorrect because the fossil record has revealed significant evidence about the evolution of species. Choice (B) is incorrect. Early fossil researchers understood the fossil record as well as possible, given the information they had at the time. Scientific knowledge changes when new information is discovered. Choice (D) is incorrect because our understanding of the fossil record has changed a lot based on examination of new evidence.

Example Item 3

DOK Level 3: This is a DOK level 3 item because the question requires the student to make choices based on a reasoned argument.

Science Grade 7 Domain: Interdependence of Life

Standard: S7L4. Students will examine the dependence of organisms on one another and their environments. b. Explain in a food web that sunlight is the source of energy and that this energy moves from organism to organism.

Standard: S7CS5a. Observe and explain how parts can be related to other parts in a system such as predator/prey relationships in a community/ecosystem.

A 1,000-pound cow needs to eat about 25 pounds of feed per day just to maintain its body weight. Which statement provides the BEST explanation of why a cow might not gain weight when fed 35 pounds of food per day?

- A. A lot of the energy the cow gets from its feed is used to produce milk.
- B. Energy is gained in the food web as the cow stores it for later use.
- C. The cow gets additional energy directly from the Sun.
- D. Energy is lost as it moves from the cow to the feed.

Correct Answer: A

Explanation of Correct Answer: The correct answer is choice (A) A lot of the energy the cow gets from its feed is used to produce milk. A great deal of energy is used in maintaining bodily functions, including milk production. Therefore, extra feed does not necessarily mean an increase of the cow's weight. Choice (B) is incorrect. Some energy is always lost as it moves through a food web. Choice (C) is incorrect because cows are heterotrophic herbivores and cannot convert the Sun's energy into food. Choice (D) is incorrect because energy is transferred from the feed to the cow, not from the cow to the feed.

SCIENCE CONTENT DESCRIPTION AND ADDITIONAL SAMPLE ITEMS

In this section, you will find information about what to study in order to prepare for the Grade 7 Science EOG assessment. This includes main ideas and important vocabulary words. This section also contains practice questions, with an explanation of the correct answers, and activities that you can do with your classmates or family to prepare for the test.

All example and sample items contained in this guide are the property of the Georgia Department of Education.

CONTENT DESCRIPTION

- Construct and use dichotomous keys based on physical characteristics in order to classify organisms
- Classify living organisms into different kingdoms according to physical characteristics
- Identify different cell structures and their functions
- Use ecosystems to explain the cycling of matter and energy
- Explain how changes in environmental conditions can affect the survival of both individuals and entire species
- Identify different relations among organisms that are competitive or mutually beneficial
- Describe concepts of natural selection and fossil evidence
- Describe the characteristics of Earth's major biomes and aquatic communities
- Use the concept of natural selection to explain how different species have evolved
- Understand how the fossil record provides evidence for how different life forms have changed through time
- Explain how the physical characteristics of organisms have changed over successive generations
- Describe the function of the major organ systems in the human body
- Describe the role of genes and chromosomes in the process of inheriting specific traits
- Compare and contrast organisms by their way of reproducing, i.e., sexually or asexually
- Explain the process of selective breeding and its consequences for organisms and humans

CHARACTERISTICS OF SCIENCE STANDARDS

- Develop a hypothesis that can be tested by experimentation
- Use safety procedures and appropriate practices in all laboratory situations and with all laboratory instruments
- Collect and analyze data, interpret results, draw conclusions, and communicate information in oral and written forms

- Use appropriate tools and instruments to observe and measure objects and phenomena
- Develop and use models to represent systems or phenomena, make predictions and inferences, test hypotheses, and support explanations
- Organize scientific information in tables, charts, and graphs, as appropriate
- Formulate scientific claims and arguments based on evidence
- Understand how science knowledge grows and changes

Unit 1: Ecology

In this unit, you will study the interdependence of life on Earth. You will demonstrate the development and use of dichotomous keys to classify organisms based on defining characteristics. You will describe major biomes and communities in which organisms live and learn to recognize the effects of changes in environmental conditions. You will begin to learn about relationships between organisms and examine the dependence of organisms on their environments.

KEY TERMS

An **organism** is any life form. All animals, plants, and single-celled life forms are organisms. Organisms are also known as **living things**. Living things can breathe, move, grow, reproduce, and—owing to this—require energy to continue living. (S7L1)

Nonliving things include dead organisms as well as objects such as minerals that never were alive. Dead organisms are still considered to be organic material, while other nonliving things are often inorganic. Nonliving things do not respond to stimuli, they cannot adapt to their environment, and they cannot evolve. Generally, if a thing does not contain cells, it would be nonliving. Nonliving things also do not show any of the characteristics of living things, such as breathing and growing. (S7L1)

The **environment** is all the living and nonliving things that surround an organism. All the factors that influence the survival, development, and evolution of an organism are also part of an environment. A change in the environment can affect the survival of the individuals or species that live in that environment. (S7L4e)

When people refer to an **ecosystem**, they are referring to the community of living and nonliving things that make up a system in an environment. The key idea is that an ecosystem is a system located within an environment. A pond with producers, consumers, and decomposers in it that is located on a mountain is an example of an ecosystem. In this model, the mountain could be considered the environment. Environmental changes in an ecosystem can affect the survival of individual animals and species within an ecosystem. (S7L4c, e)

A general type of an ecosystem is known as a **biome**. A biome is defined by local climate patterns and types of plants that can be found in the biome. A savanna in Africa is warm, is dry, and has a lot of grasslands. A stream on your way to school is a freshwater biome. The water is warm, flows, and contains algae as a producer. (S7L4e)

Terrestrial biomes are those biomes that are on land. Rain forests, savannas, deserts, tundras, and mountains are examples of terrestrial biomes. (S7L4e)

Aquatic communities are biomes found in water. Scientists divide aquatic communities into two regions: freshwater and marine. Freshwater aquatic communities are areas that have water with low salt levels, such as ponds, lakes, streams, rivers, and wetlands. Marine aquatic communities have higher salt levels and include oceans, coral reefs, and estuaries. (S7L4d)

The populations and interactions of two or more species in a geographical area are known as a **community**. In a community, separate populations impact each other's behavior and survival. (S7L4d)

Interdependency describes how species rely on each other to meet their needs. Consumers are dependent on producers as a source of energy. In some cases, being dependent can be **mutually beneficial**. Some birds eat berries whole. They are dependent on the berry plant as a source of energy. The berry plant benefits from this relationship because the birds will release some of the berry seeds into other areas, so the berry plant as a species can reproduce. (S7L4d)

When organisms or species interact and one of those organisms or species has some aspect of its ability to survive impacted, they are said to be **competitive**. Ants and beetles compete for the same types of food. Sparrows will compete for living space with martins by stealing the martins' nests. (S7L4d)

You **classify** things when you organize them into groups based on characteristics they share. Scientists classify things so they can study ways those things are similar or different. A classification system can be used to identify and study that species. (S7L1b)

Living things are classified using a **six-kingdom system**. The six kingdoms are animals, plants, fungi, protists, archaeobacteria, and eubacteria. The earliest method to classify living things used a two-kingdom system of animals and plants. As scientists started studying organisms with microscopes, they realized that some organisms did not fit their classification as either an animal or a plant. This gave rise to the additional four kingdoms. (S7L1a)

A **dichotomous key** is a tool that helps identify organisms based on making a choice between two characteristics. People develop dichotomous keys by starting at a characteristic that two organisms have in common, such as flying. Bats, wasps, and robins fly. The next step would be to find some common characteristic that at least two of those flying animals share. This step is repeated until the dichotomous key leads to clearly identifying a species by separating it from the others based on traits. Dichotomous keys are often revised as they are developed. (S7L1a)



Important Tip

 The way scientists have classified organisms has changed over the years. In the earliest systems, organisms were either a plant or an animal. Scientists have learned to base their classification on similar body structures rather than functions. For example, dolphins and sharks both live in the water, swim, and are gray. However, dolphins are mammals and have lungs, and sharks are fish and have gills. Scientists classify based on similar genetic backgrounds that have led to having similar body structures. When you work on classifying organisms, keep in mind that you should look for similar traits and that new information may require you to modify your classification system. (S7L1a)

Sample Items 1–2

Item 1

A science class develops its own dichotomous key for identifying animals with hooves.

Dichotomous Key for Orders of Mammals			
Step 1	1a	Has long trunk	Proboscidea
	1b	Does not have long trunk	Go to Step 2
Step 2	2a	Has limbs with fingers and toes	Primate
	2b	Does not have limbs with fingers and toes	Go to Step 3
Step 3	3a	Has limbs with sharp claws, not hooves	Go to Step 4
	3b	Has limbs with hooves, not claws or nails	Go to Step 5
Step 4	4a	Has sharp teeth and eats meat	Carnivore
	4b	Eats insects	Insectivore
Step 5	5a	Has limbs with even-toed hooves 	Artiodactyla
	5b	Has limbs with odd-toed hooves 	Perissodactyla

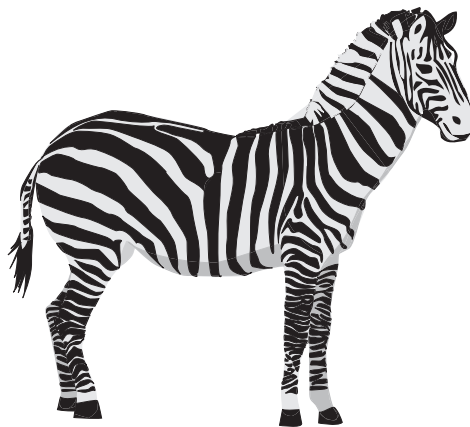

Zebra



Zebra hoof

Using the dichotomous key, to which order does the zebra belong?

- A. Artiodactyla
- B. Carnivore
- C. Perissodactyla
- D. Proboscidea

Item 2

Four different biomes are described in a table.

	Type of Organisms	Humidity Level
Biome 1	Trees and lichen	Relatively dry
Biome 2	Grasses and shrubs	Very dry
Biome 3	Evergreen trees	Relatively humid
Biome 4	Mangrove trees	Very humid

Which biome represents the type of ecosystem of a desert?

- A. Biome 1
- B. Biome 2
- C. Biome 3
- D. Biome 4

Unit 2: Energy Flow and Nutrient Cycling

In this unit, you will recognize the source of energy in ecosystems and learn how energy and matter are transferred through organisms in a food web and recycled by organisms and their environment. You will identify roles that different types of organisms play within communities and study ways that organisms can affect each other and their environment.

KEY TERMS

When you look at more than one food chain in an ecosystem, you are looking at a **food web**. Food chains show how a specific combination of organisms obtain the matter and energy they need from each other. A food web is all the food chains put together. It looks like a web because it shows how all the different organisms in all the combined food chains interact to obtain the matter and energy they need. The only thing in a food web that is not an organism is the Sun. (S7L4a, b)

There are three categories of organisms in a food web. **Producers** are organisms that make their own food by converting energy from sunlight into glucose, which is then used to make energy for growth and survival. **Consumers** are organisms that feed on other organisms to get the energy they need to grow and survive. They cannot make their own food using energy from sunlight. **Decomposers** are organisms that feed on dead organisms and decaying matter to get the energy they need for growth and survival. They help break down matter into nutrients and release it back into the environment to be recycled.

The **primary source of energy** in all food webs is the Sun. The Sun provides the energy that plants (producers) use to make their own energy. When plants are eaten by animals (consumers), the animals receive some of the energy from the plant that the plant received from the Sun. When other animals eat those animals, they receive some of the energy that the first animal received when they ate the plants. Energy in a food web is passed from one organism to another. (S7L4a)

As **energy transfer** occurs through a food web, energy is lost as it moves from one organism to another. When an animal eats a plant, most of the energy received from the plant is used by the animal's life functions, such as growing and reproducing. Roughly 10% of the energy from one organism is passed on to the next organism. (S7L4 b)

When an organism eats another organism, there is a **matter transfer**. The animal that takes in matter breaks down that matter for use by its cells for repairing and growing its own body. In a food web, no matter is lost. Matter recycles through food webs. For example, a deer eats hay. Some of that hay is converted into muscle and other organs in the deer. Decomposers in turn break down the hay that the deer doesn't digest. When the deer dies, other animals might eat some of the deer. Decomposers will also break down parts of the deer that animals will not. None of the matter is lost; it is simply converted into other forms of matter. (S7L4a)

Decomposers are responsible for the largest share of matter transfer in a food web because they break down all organisms. Decomposers are processing matter and releasing the energy, in the form of heat, trapped inside the matter. Steam can be seen rising from compost piles. That steam is water that is heated to a vapor by the heat being released by the decomposers in the compost pile. (S7L4a, b)

In a food web, both matter and energy are transferred from organism to organism. Because of this, organisms have a **dependence** on each other. Animals that eat plants depend on some plants to provide the animals with energy. Sometimes animals depend on plants to provide shelter for their survival. (S7L4d)

Some organisms have relationships that are said to be **mutually beneficial**. A mutually beneficial relationship is one where each organism receives a benefit from the other organism. For example, a flower provides nectar for a butterfly. The butterfly benefits by receiving energy from the nectar. Because the nectar is near the pollen of the flower, the butterfly gets some of the pollen on its legs and wings. When the butterfly gets nectar from another flower, the pollen rubs off onto the other flower. This benefits the flower because it helps the flower reproduce. (S7L4d)

Another type of relationship two organisms can have is a **competitive** relationship. In some environments, organisms will compete for the same resources. Competition can occur between two animals of the same species, such as when two red-tailed hawks compete for a hunting territory. Competition can also occur between two different species. Red-tailed hawks compete with great horned owls for prey. Both species hunt at twilight so they are competing with each other to get the same prey. (S7L4d)

Important Tip

✍ Every food web requires a balance between all the organisms within the food web. If one species is removed or reduced below a certain point, the food web can become unbalanced. This can happen due to natural causes or man-made causes. Europeans brought rabbits and red foxes to Australia so they could be hunted for sport. However, it turns out that neither species have direct competition. The rabbits eat large amounts of vegetation and are prolific breeders. Foxes are prolific hunters. Because both species have little competition in the food webs in Australia, both are considered high to extremely high threat levels to the balance of the food webs they inhabit in Australia. (S7L4d)

Sample Items 3–8

Item 3

A food web from a meadow ecosystem is represented in the diagram.

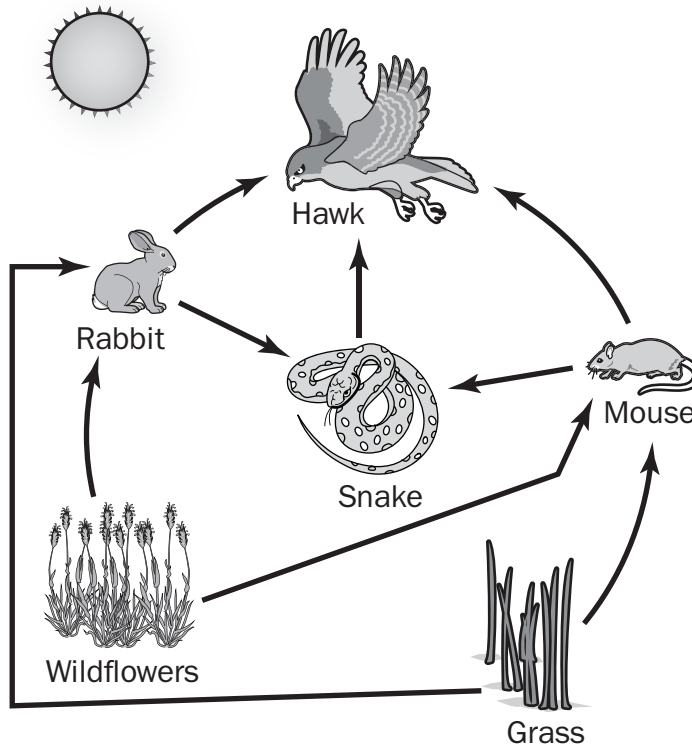

Which pathway correctly shows how the hawk receives energy?

- A. Sun → hawk
- B. Sun → grass → hawk
- C. Sun → wildflowers → snake → hawk
- D. Sun → grass → mouse → snake → hawk

Item 4

In a marine ecosystem, clownfish often hide in the tentacles of the poisonous sea anemone. The clownfish are covered with a thick mucus layer, which protects them from the sea anemones' poison. Uneaten scraps of clownfish meals provide the sea anemone with food.

Which of these **BEST** describes the relationship between the clownfish and sea anemone in this ecosystem?

- A. competitive
- B. mutualism
- C. parasitic
- D. predator-prey

Item 5

Matter is transferred from one organism to another in food webs. Which of these describes one of the ways in which matter transfer happens?

- A. The Sun provides energy to decomposers.
- B. The Sun provides energy to consumers.
- C. Consumers provide nutrients to producers.
- D. Producers provide nutrients to consumers.

Item 6

The European green crab is native to European coasts. It was introduced to American coasts in the middle of the 18th century. The green crab feeds on shore crab, green algae, clams, and oysters.

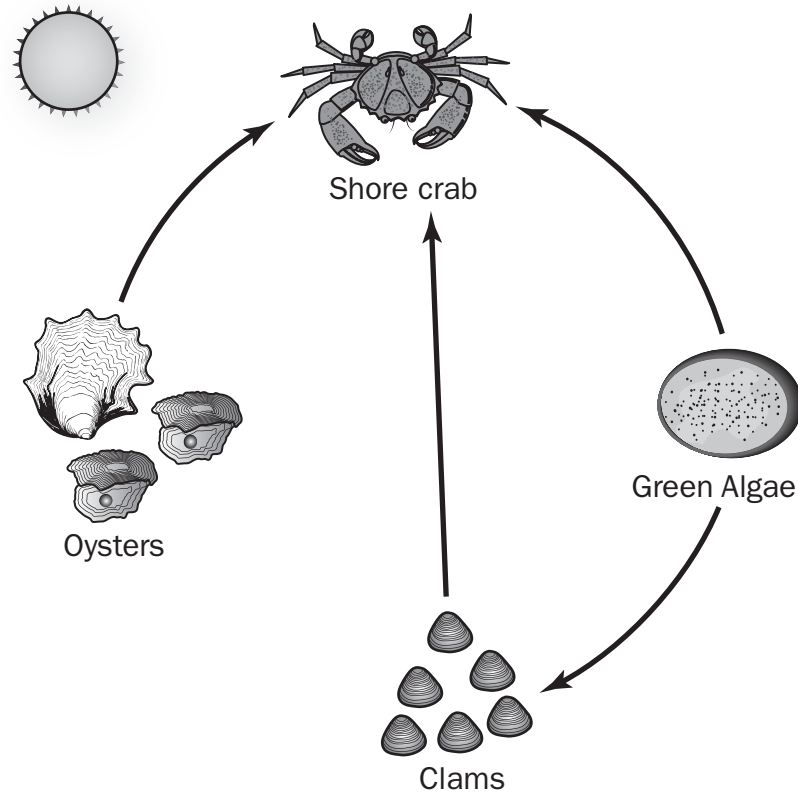

What effect does the introduction of the European green crab into this food web have on the transfer of matter from one organism to another?

- A. The European green crab will reduce the amount of matter transferred to green algae.
- B. The European green crab will increase the amount of matter transferred from the shore crab to the clam.
- C. The European green crab will decrease the amount of matter transferred from the shore crab to the clam.
- D. The European green crab will reduce the amount of matter transferred from the clams to the shore crab.

Item 7

A fire destroys all the grasses in a prairie ecosystem. The field mice living in the prairie no longer have the protection of dense vegetation in their habitat. Over the course of a year, the grasses do not grow back.

Which of these is the **MOST LIKELY** effect on the population of field mice?

- A. The population will move or die out.
- B. The population will increase in number or diversity.
- C. The population will develop new behaviors and remain there.
- D. The population will change color to blend in with the new habitat.

Item 8

The food web shows the transfer of energy in a salt marsh ecosystem.

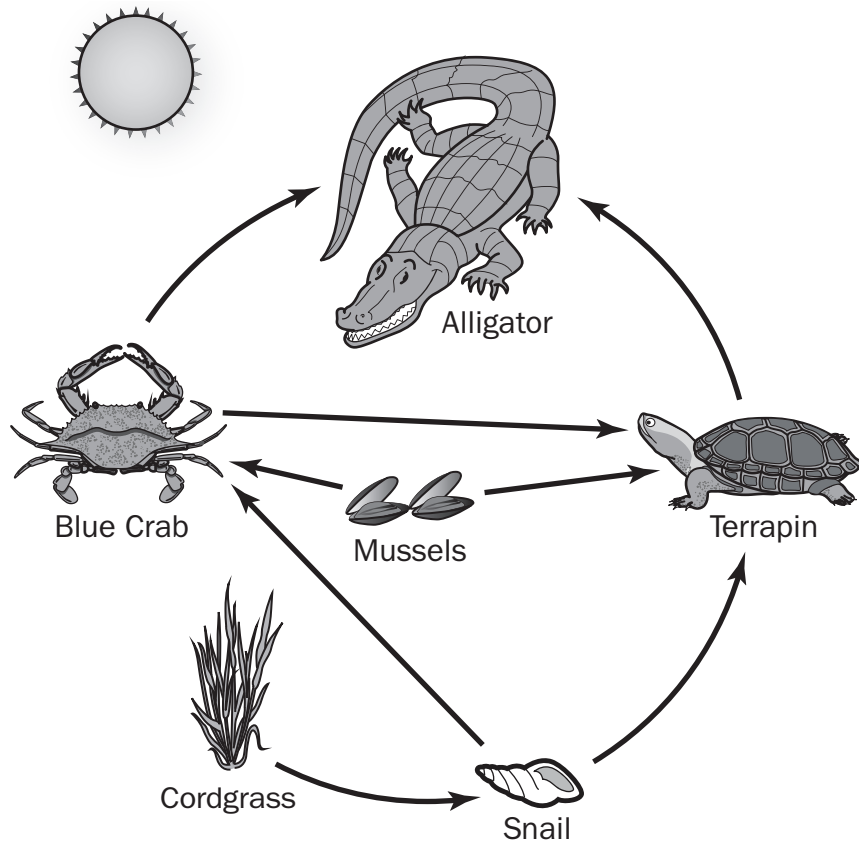

This diagram shows the movement of energy from organism to organism in an aquatic food web. Which pathway shows the correct flow of energy in the food web?

- A. alligator → terrapin → snail → cordgrass → Sun
- B. Sun → cordgrass → snail → blue crab → alligator
- C. Sun → cordgrass → snail → terrapin → blue crab → alligator
- D. cordgrass → snail → terrapin → alligator → cordgrass → Sun

Unit 3: Structure and Function of Cells

In this unit, you will study the organization of individual cells. You will identify the different parts of cells and explain their functions. You will study the processes carried out by cells in order for organisms to survive and reproduce.

KEY TERMS

Cells are the smallest unit of life and make up all living things. Cells perform basic life functions such as the breakdown of molecules that serve as sources of energy, obtaining and transporting substances necessary for growth, getting rid of waste, and reproduction. Cells can look different and perform different roles in an organism. There are many different types of cells including, but not limited to, animal, plant, and bacterial. All cells come from other cells. (S7L2a)

Organelles are the specialized elements that form a cell. Organelles are to cells as organs are to the body. (S7L2a)

Cells are made up of many different organelles. This table shows where you will find some cell **structures**. Some of the **functions** of these cell structures are also listed. (S7L2a, b)

	Animal Cell	Plant Cell
Cell Membrane	outer layer of the cell	separates the cell wall from everything inside the cell
Nucleus	the part that controls all the activity in a cell	the part that controls all the activity in a cell
Chloroplast	not found in animal cells	<ul style="list-style-type: none"> found in plant cells produces sugar for the plant to use and to store
Cytoplasm	<ul style="list-style-type: none"> the fluid and cell organelles found within the cell all cell activity happens in the cytoplasm 	<ul style="list-style-type: none"> the fluid and cell organelles found within the cell all cell activity happens in the cytoplasm
Mitochondria	produces the energy supply for the cell	produces the energy supply for the cell
Cell Wall	not found in animal cells	<ul style="list-style-type: none"> outer layer of a cell provides support and structure to cell most plant cell walls are rigid

Cells are involved in many processes including **osmosis, diffusion, and photosynthesis**. They use a cell part or parts in these processes. (S7L2a)

Cell membranes act as a filter that allows nutrients and other materials in and out of cells. In animal cells, the cell membrane is the outermost layer of the cell. Animal cells do not have a definite shape. In plant cells, the cell membrane is contained within the cell. The cell wall in plants is the outermost layer of the cell. (S7L2a, b)

The **cell wall** is the outermost layer of plant cells. It is mostly rigid and accounts for the rectangular shape of plant cells. Animal cells do not have cell walls. (S7L2a, b)

The **nucleus** of a cell is the organelle that controls the activities of the cell. The nucleus also contains the genetic material for the cell. (S7L2a, b)

Mitochondria are the organelles that produce most of the energy for the cell. Mitochondria are also responsible for maintaining the life cycle of a cell and cellular differentiation. The number of mitochondria within a cell depends on the type of tissue the cell makes up. Organs that require more energy, such as most muscle tissue and the liver, contain more mitochondria. (S7L2a, b)

Cell differentiation is the process that produces cells that are **specialized** to certain functions. Muscle cells are designed to process energy in and out very rapidly. The cells that make up bone marrow tissue are specialized to produce blood cells. (S7L2a, b)

Chloroplasts are organelles found only in plants. The chloroplasts use the energy from sunlight to combine oxygen and carbon dioxide to produce sugars for use in the plant and for storage. (S7L2a, b)

Cytoplasm is made up of a gel known as cytosol and the organelles that are found within a cell. Cytoplasm helps move nutrients in and out of the cell by acting as a pump that controls the movement of those nutrients. (S7L2a, b)

Sample Items 9–11

Item 9

What will happen to a cell if it CANNOT take in nutrients?

- A. The cell will recycle waste products to use in place of the nutrients.
- B. The cell will speed up cell division to obtain more energy.
- C. The cell will be unable to obtain energy for cell division.
- D. The cell will start producing nutrients internally.

Item 10

In cells, different parts interact to provide needed energy. Animal cells and plant cells have many similar structures that perform similar functions.

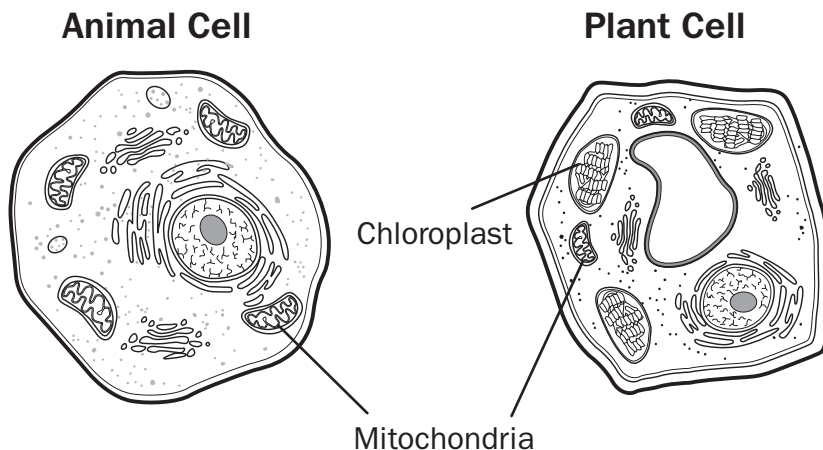

What is the relationship between the two cell structures?

- A. Chloroplasts use glucose to make energy, and mitochondria use energy to make glucose.
- B. Chloroplasts use energy to make glucose, and mitochondria use glucose to make energy.
- C. Chloroplasts and mitochondria transform solar energy into chemical energy for the cell.
- D. Chloroplasts and mitochondria both make and store chemical energy in their structures.

Item 11

If the mitochondria in a cell stop functioning correctly, what effect does this have on the whole cell?

- A. Cellular division would increase.
- B. The cell would not have enough energy to function.
- C. The cell would organize itself into tissues more quickly.
- D. The nucleus would take over the functions of the mitochondria.

Unit 4: Organization of Life

In this unit, you will study the levels of organization within organisms, from the simplest functional units to the most complex. You will distinguish between tissues, organs, and organ systems and identify how they serve the needs of cells. You will explain the function of organ systems and how these systems work together to maintain balance within the human body.

KEY TERMS

Multicellular organisms have **levels of organization**. Cells are organized into tissues. Tissues are organized into organs. Organs are organized into organ systems. Organ systems are organized into the organism. (S7L2c)

Tissues are made up of cells that are functionally similar and work together to perform specific activities. Blood, bone, and nerves are examples of tissues. (S7L2c)

Organs are made up of different types of tissues that work together to perform a specific function. The heart and brain are examples of organs. (S7L2c)

Organ systems are a group of organs that work together to perform a specific function. The respiratory system is an example of an organ system. It includes organs like the lungs, the diaphragm (the muscle that pulls on the lungs and draws air in), the windpipe and the bronchi, which are the tubes that air flows down to get into the lungs. (S7L2c)

An **organism** is the individual life form that is made up of the cells, tissues, organs, and organ system within its body. (S7L2c)

The functions of the **major organ systems** in the human body are to conduct the processes of digestion, respiration, reproduction, circulation, excretion, movement, control, coordination, and protection from disease. (S7L2e)

Digestion is the function that brings nutrients into the body. The digestive tract starts in the mouth where the organs such as the tongue, saliva glands, and teeth contribute to breaking the food down. After you swallow food, it goes down to the stomach where acid breaks the food down into smaller pieces. From there, the intestines absorb the nutrients and water. The digestive tract ends where your body expels the waste materials from eating and drinking. (S7L2e)

Respiration is the function that brings needed oxygen into the body and expels carbon dioxide as a waste product. The respiratory system is made up of the lungs, trachea, bronchi, and diaphragm. The diaphragm is a muscle that pulls down on the lungs. This causes air to move down through the trachea and bronchi into the lungs. Tissues within the lungs take oxygen into blood cells and remove the carbon dioxide. The carbon dioxide is removed from the lungs when you exhale. (S7L2e)

The **reproductive system** is differentiated by gender in humans. The male reproductive system's sole function is to deposit sperm for reproduction. The female reproductive system has two purposes: the production and release of eggs for fertilization and the protection and nourishment of the offspring until birth. The purpose of the reproductive system is to ensure the continuation of a species. (S7L2e)

The **circulatory system**, also known as the cardiovascular system, permits blood to circulate. Blood moving through the body carries nutrients, oxygen, carbon dioxide, hormones, and blood cells. The movement of blood throughout the body helps the

body stay healthy. The circulatory system is made up of the heart, veins, and arteries. Humans have a heart with four chambers. (S7L2e)

Excretion is carried out in the human body by the kidneys, liver, large intestine, and skin. The excretory system removes waste products as well as excess and unnecessary materials from the body. The human body cannot stay healthy with waste products and excess materials inside the body. (S7L2e)

The skeletal and muscular systems along with connective tissues combine to control movement in humans. This allows the body to move, supports the body, and protects the organs in the body. (S7L2e)

Control of the human body is carried out by two major organ systems: the **nervous system** and the **endocrine system**. The nervous system is made up of the brain, spinal cord, retina, and other nerve systems that connect to it. The endocrine system is made up of eight organs that release hormones into the blood stream to control the metabolism and growth of the human body. (S7L2e)

Coordination in the human body is carried out by the nervous system. Voluntary and involuntary actions are transmitted and carried out throughout the body by the nervous system. Voluntary actions are actions that are carried out by choice. Running, sitting, and getting dressed are examples of voluntary actions. Involuntary actions are actions that occur without making a conscious choice. Coughing, sneezing, and hiccups are examples of involuntary actions. (S7L2e)

The immune system is the organ system used by the human body to get **protection from diseases**. Lymph nodes, bone marrow, the spleen, and white blood cells are part of this system. The lymph system distributes lymph, a clear fluid that contains white blood cells, to areas of the body. White blood cells help to fight diseases by producing antibodies that harm infections. White blood cells will also absorb infectious agents to control them. (S7L2e)

Important Tips

- ✎ Cell theory is the foundation of biology and has three central tenets:
 1. All living organisms are composed of one or more cells.
 2. The cell is the most basic unit of life.
 3. All cells arise from pre-existing living cells.
- ✎ Humans had always tried to identify the process that led to living things. Many hypotheses were suggested. The most common theory was that life arose due to spontaneous generation. People saw that maggots would come out of dead flesh and so they believed this was confirmation of the hypothesis. Our knowledge of cells and cell theory developed rapidly with the creation of the microscope. This tool allowed scientists to see what cells looked like. After scientists identified cells, they started creating hypotheses and theories to explain what they saw. Modern cell theory has added four additional tenets to the theory. As scientists expand our knowledge of cells, more tenets may follow. (S7L2)
- ✎ The different organ systems do not operate independently from one another. Often a few systems coordinate to maintain homeostasis, the process that keeps the internal conditions within a body stable. For example, the endocrine system will release hormones when you get hungry. The circulatory system will carry those hormones to the brain. Your brain sends a message along the nervous system to tell you that you are hungry. (S7L2d, e)

Sample Items 12–15

Item 12

Your body gets cold and you start to shiver. Which organ systems are responsible for your response to the cold?

- A. skeletal, muscular, and immune
- B. skeletal, circulatory, and nervous
- C. immune, excretory, and circulatory
- D. circulatory, muscular, and nervous

Item 13

Which of these BEST describes the relationship between tissues and organs?

- A. Tissues make up different types of cells.
- B. Organs make up different types of tissues.
- C. Cells are made of different types of organs.
- D. Organs are made of different types of tissues.

Item 14

Which of these correctly compares how systems remove wastes from the human body?

- A. The respiratory system removes wastes from the heart and lungs, and the skin removes wastes from all other organs.
- B. The respiratory system removes wastes in the form of gases, and water and some salts are removed through the skin.
- C. Waste from the heart and lungs is removed through the skin, and the respiratory system removes wastes from other organs.
- D. Waste is removed through the skin in the form of gases, and the respiratory system removes wastes in the form of liquids.

Item 15

A loud noise startles you, causing you to jump out of your chair. How do your organ systems work together to produce your response?

- A. Your immune system senses danger and sends a signal through your nervous system. That system sends a signal to your muscular system, and you jump out of your chair.
- B. Your muscular system works with your skeletal system to move your body, causing your nervous system to speed up the circulatory and respiratory systems.
- C. Your circulatory system speeds up your heart, making it beat faster. In response, your respiratory system makes you breathe harder.
- D. Your nervous system responds to the sound. Your nervous system then sends a signal to your muscular system, and you jump out of your chair.

Unit 5: Biological Traits and Heredity

In this unit, you will study how biological traits are passed on through generations. You will explain the roles of genes and chromosomes in the process of inheritance. You will compare different methods of reproduction and learn how selective breeding can be used to produce desired traits in organisms.

KEY TERMS

In genetics, an **inherited trait** is a physical characteristic of an organism that is inherited from the parents. The color of your eyes is a trait. Your genes will determine your physical traits, such as the ability to roll your tongue, the presence of dimples, the presence of freckles, and hair color. Other traits, such as height and weight, might be affected by your genes but will not be completely determined by genes. (S7L3a)

Selective breeding is the process of breeding organisms with **desirable traits** for the purpose of producing offspring that also carry that desirable trait. For example, turkeys that have larger chests will carry more meat, so if you want turkeys with more meat, you breed the turkeys with larger chests. The advantage to selective breeding is that it can have good effects, such as producing plants that grow using less water or require less sunlight. The disadvantage is that it reduces genetic diversity. Crops such as bananas and potatoes can be struck down by a number of diseases because humans have used selective breeding to breed those crops to grow quickly rather than for their resistance to diseases. (S7L3a, c)

A **gene** is a biological structure that carries the instructions that a cell needs to make molecules called proteins and pass genetic traits to offspring. Multiple genes are grouped together to form structures that are called chromosomes, which are found in the nucleus of the cell. All cells, with the exception of the cells related to sexual reproduction, contain two copies of each gene. One paired gene comes from one parent, while the other paired gene comes from the other parent. Traits are the result of the mixing of the pairs of genes. Usually a number of gene pairs are involved in any one trait. Most genes have two or more variations, called **alleles**. Often one allele will be **dominant** and one will be **recessive**. A recessive allele is usually expressed only in the absence of a dominant allele. An organism may inherit two identical or two different alleles from its parents. Genes can contribute to the survival of a species when they produce traits that are more likely to keep that species alive, such as camouflage in animals. (S7L3a)

Gene **expression** happens when the instructions from a gene are carried out to give rise to the organism's inherited characteristics. In most cases, the information carried in the genes is used in the formation of proteins and other molecules. (S7L3a)

Chromosomes are structures that carry groups of genes in bundled-up strands known as **DNA**. Every living thing has a set of chromosomes in every cell. The number of chromosomes in each species is different. Humans have 23 pairs of chromosomes, for a total of 46 chromosomes per cell. A change in the number of chromosomes can cause problems with growth, development, and function of the body's systems. Goldfish have between 100 and 104 chromosomes. Cultivated tobacco has 48 chromosomes. (S7L3a)

Sexual reproduction is the process of creating a new organism by combining genetic material from two organisms. The genes the offspring inherit are a mix of the genes from the two parents. Of the six kingdoms, all animals, most plants, some fungi, some eubacteria, and some archaebacteria reproduce by sexual reproduction. (S7L3b)

Asexual reproduction is the process of creating a new organism from a single organism. The genes that the offspring have are identical to the genes of the parents. Of the six kingdoms, protists, eubacteria, some archaeobacteria, some fungi, and some plants reproduce by asexual reproduction. (S7L3b)

Important Tip

✍ A **mutation** is a genetic error that occurs when the instructions contained in a gene are read incorrectly. There are processes within chromosomes that work to remove these errors. Sometimes a mutation can slip through the process to remove the errors. Most mutations end up having no effect on the cell or the organism. People often think that mutations are a bad thing. However, mutations create genetic variation within individuals in a species. This helps create genetic diversity within the species. Variations that increase the survival of a species can then be carried on to future generations. Mutation can be caused when errors are accidentally created from the instructions from the gene. Mutations can also be caused by agents in the environment, such as ultraviolet rays from the Sun, radiation, and chemicals.

Sample Items 16–19

Item 16

Water fleas live in freshwater environments. In the spring, water fleas reproduce rapidly to ensure an adequate population of the species. In the fall, water fleas have more time to produce offspring that are more genetically diverse.

	Mode of Reproduction	Effect on Gene Pool	Energy Requirement	Occurs in...	Time to Reproduce
Asexual	One Parent	Genetically identical	Less	Simple and complex organisms	Less time is required
Sexual	Two Parent	Genetic variation	More	Simple and complex organisms	More time is required

Based on the information in the table, which type of reproduction should water fleas use during each period?

- A. asexual reproduction in the fall when more offspring are needed for winter; sexual reproduction in the spring when the offspring have less time to develop
- B. asexual reproduction in the spring when offspring are needed to populate the species; sexual reproduction in the fall when offspring have time to develop
- C. asexual reproduction throughout the year to increase the likelihood of offspring survival, regardless of environmental changes
- D. sexual reproduction throughout the year to ensure diversity in the species,

regardless of environmental changes

Item 17

Genes are segments of DNA that contain “instructions” for the expression of traits. The presence of just one dominant gene in a chromosome pair results in expression of a certain trait. A recessive gene, on the other hand, will only result in the expression of a trait if the gene appears in both paired chromosomes.

In guinea pigs, the gene for black coat color is the dominant gene, and the gene for white coat color is the recessive gene.

A guinea pig has a black coat. Which of these provides the BEST explanation about the guinea pig’s parents?

- A.** The guinea pig received a recessive gene for white coat color from one parent and no gene for coat color from the other parent.
- B.** The guinea pig received a dominant gene for black coat color from one parent and no gene for coat color from the other parent.
- C.** The guinea pig received a dominant gene for black coat color from one parent and a recessive gene for white coat color from the other parent.
- D.** The guinea pig received a recessive gene for white coat color from one parent and a recessive gene for white coat color from the other parent.

Item 18

A farmer wants to create a new breed of tomato that is sweet-tasting, has a very low quantity of seeds, and grows well in the hot and humid Georgia climate.

The table shows the traits of four tomato plant varieties.

Tomato-Plant Traits							
Plant	80 Seeds/Kg	40 Seeds/Kg	10 Seeds/Kg	High Sugar Content	Deep Red Color	Grows Best in Dry Climates	Long Ripening Time
1	x			x	x	x	x
2			x			x	x
3		x			x	x	
4		x		x			

Which plants should the farmer select as parents to have the highest chance of producing a tomato plant with the desired traits?

- A. Plant 1 and Plant 2
- B. Plant 2 and Plant 3
- C. Plant 1 and Plant 4
- D. Plant 2 and Plant 4

Item 19

A mare is a female horse. Mare A is a fast horse with moderate muscle mass. Mare B is a fast horse with large muscle mass. Both mares are bred with a fast, muscular male horse. After receiving identical training and diets, the two offspring run on a track and their runs are timed.

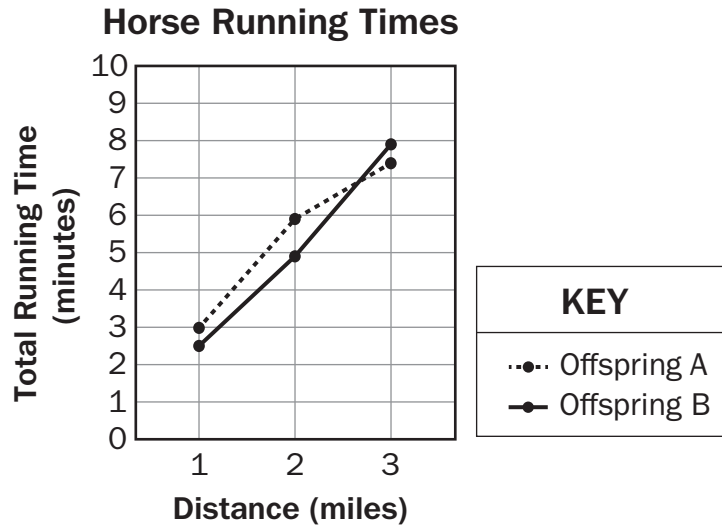

Using selective breeding, which mare should be used to breed horses for speed, and which mare should be used to breed horses that have the best chance of running for the longest time?

- A. Mare A should be bred for speed, and Mare B should be bred for endurance.
- B. Mare A should be bred for endurance, and Mare B should be bred for speed.
- C. Both Mare A and Mare B should be bred for endurance as the desired trait.
- D. Both Mare A and Mare B should be bred for speed as the desired trait.

Unit 6: Evidence of Evolution

In this unit, you will study the evolution of organisms. You will explain the process of natural selection by which the physical characteristics of organisms change over successive generations. You will trace changes in life forms through the fossil record and recognize that fossils provide evidence for a long history of change.

KEY TERMS

Inherited characteristics are the physical characteristics of an organism inherited from its parents. The color of your eyes is an inherited characteristic, also called a trait. The differences that are possible in a specific trait, such as eye color, are referred to as **variation**. The genes you inherit will determine your physical characteristics such as eye and hair color. Other characteristics, such as height and weight, might be affected by your genes but will not be completely determined by genes. (S7L5a)

Evolution is the modification of a species over **successive generations**. Evolution can also refer to the development of several species from one common ancestor species. Whales are a good example of evolution. Whales are mammals with some hair and lungs, but they live in aquatic environments like fish. Fossils of the earliest whales strongly resemble the fossils of a group of scavenging carnivorous land-based mammals. The most notable difference in the fossils are that the teeth of the whales look very much like the teeth of fossils from later generations of whales and not like the teeth of the mammals. Later whale fossils, roughly 20 million years younger than the earliest whales, have large hands and feet with webbing. The toes are hooved much like the older land-based mammals. Whale fossils from a few million years after that show modifications of the hand and feet into flippers. (S7L5a, b, c)

The **fossil record** shows the point where a species changed enough to be considered a different species but still shared the majority of its traits with a common ancestor. The whale fossil record, for example, also shows a clear change in the species over successive generations. One of the biggest challenges in following clear paths of evolution for a species is finding fossils of successive generations of a species. It is not always apparent when there are changes in a species. (S7L5c)

Natural selection is the process whereby nature selects which members of a species survives based on certain traits. Suppose there is a population of mice that live in a field that is full of tan-colored dry grass. There are black mice and tan mice. The predators in the area can see the black mice easier and eat more of the black mice because they are easier to locate. Over time, the mice that carry the genes for a tan coat survive more often than the mice with black coats. This increases the population of tan mice and increases the likelihood that the majority of future generations will be tan. (S7L5b)

Important Tip

 It is important to understand that evolution does not necessarily result in “improvement” or greater complexity of organisms. Many fossil findings demonstrate that life does not always steadily evolve from simple to complex. For example, fossils in the Burgess Shale site in the Canadian Rocky Mountains have revealed that quite complex organisms existed more than 540 million years ago. Examples of most major groups of modern animals were discovered in this fossil deposit. (SL5b)

Sample Items 20–24

Item 20

Which of the following BEST describes the effect that natural selection might have on a species over time?

- A. The fur color of a species will always change over time, because of natural selection.
- B. Predator species will always increase due to natural selection, while prey species will always die out.
- C. Members of a species with traits that allow them to survive and reproduce in an environment will increase in population, while those without those traits will die.
- D. Bigger members of a species always have an advantage over smaller members. Therefore, over time, a species will eventually include larger organisms only.

Item 21

The walking catfish is a species of fish that walks on land using its pectoral fins. During drought conditions, when there is little water in its habitat, the walking catfish can use its pectoral fins to get to areas with water.

Which of these will MOST LIKELY happen to a population of walking catfish over time if all nearby aquatic environments dry up permanently?

- A. Walking catfish with small pectoral fins are more likely to survive a trip to distant areas of water. The population is likely to evolve to have smaller pectoral fins.
- B. Walking catfish with large pectoral fins are more likely to survive a trip to distant areas of water. The population is likely to evolve to have larger pectoral fins.
- C. Walking catfish with large pectoral fins and those with small pectoral fins are equally likely to survive a trip to distant areas of water. Both types survive, so evolution is unlikely to occur.
- D. Walking catfish with large pectoral fins and those with small pectoral fins are equally likely to not survive the trip to distant areas of water. Both types of catfish will then become extinct.

Item 22

Scientists find fish fossils in Rock Layers B and C of a canyon. The fossil found in Rock Layer B is similar to the fossil found in Rock Layer C.

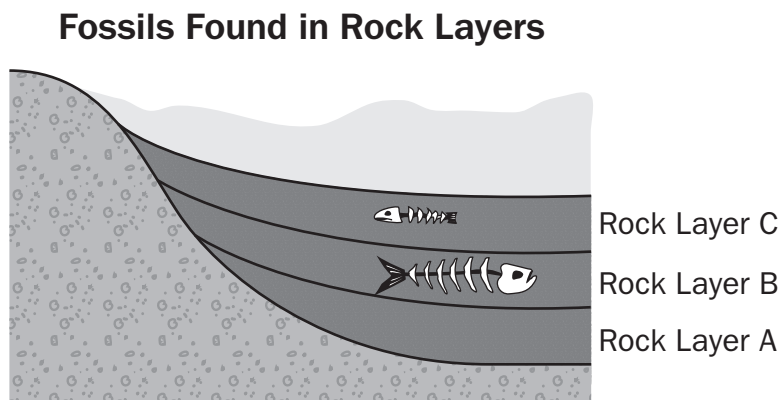

Which conclusion is **BEST** supported by the order of the layers?

- A. The two fossils are different species, because they are in adjacent layers.
- B. The two fossils are the same species, because they are in adjacent layers.
- C. The species in Layer C may have evolved from the species in Layer B.
- D. The species in Layer B may have evolved from the species in Layer C.

Item 23

A science class takes a field trip to a rock formation known for the many fossils it holds. A student finds a fossil that shows a plant with leaves similar to those of a plant that grows nearby. The student tells his classmates that the plants must be an ancient species that has not changed much over time.

Which statement **BEST** describes the student's claim?

- A. The claim is reasonable because plants do not change over time.
- B. The claim is reasonable because fossils are records of things that lived long ago.
- C. The claim is not reasonable because plants must change over time.
- D. The claim is not reasonable because fossils can be made from recently living organisms.

Item 24

Fire ants in the southeastern United States were accidentally introduced over seventy years ago. Stings from fire ants can be deadly to the native fence lizard. Fence lizards that have lived in areas with fire ants for many generations have longer legs than fence lizards that have not lived in areas with fire ants until more recently.

Which statement BEST describes how the legs of the fence lizard changed over time?

- A.** Over time, fence lizards with longer legs were more likely to survive and passed this trait on to offspring.
- B.** Over time, fence lizards stretched their legs to increase leg length and passed this trait on to their offspring.
- C.** The lizards of each generation are born without longer legs. They then grow the longer legs to avoid stepping on the fire ants.
- D.** The lizards living in areas where fire ants were first introduced used the venom from fire ants to grow longer legs. The trait for longer legs was then passed on to offspring.

SCIENCE ADDITIONAL SAMPLE ITEM KEYS

Item	Standard/ Element	Characteristics of Science	DOK Level	Correct Answer	Explanation
1	S7L1b	S7CS3d	2	C	The correct answer is choice (C) Perissodactyla. The zebra belongs to the order Perissodactyla because it has hooved limbs and odd-toed hooves. Choice (A) is incorrect because a zebra has odd-toed (1) hooves, and an Artiodactyla has even-toed (2) hooves. Choice (B) is incorrect because in order to get to Carnivore, an incorrect selection in Step 3 was made. Step 3a would have been answered as yes, when it should have been answered as no. Choice (D) is incorrect because the order Proboscidea applies only to animals with trunks, and the zebra does not have a trunk.
2	S7L4e	S7CS3d	2	B	The correct answer is choice (B) Biome 2. Deserts have low humidity. Choices (A), (C), and (D) describe biomes with higher humidity and show plants that do not grow in deserts.
3	S7L4b	S7CS5a	2	D	The correct answer is choice (D) Sun → grass → mouse → snake → hawk. Choice (A) is incorrect because hawks do not get energy directly from the Sun. Choice (B) is incorrect because hawks do not get energy directly from grass. Choice (C) is incorrect because snakes do not get energy directly from wildflowers.

Item	Standard/ Element	Characteristics of Science	DOK Level	Correct Answer	Explanation
4	S7L4d	S7CS5a	2	B	<p>The correct answer is choice (B) mutualism. Mutualism is a symbiotic relationship in which both species benefit. In this case, both the clownfish and the sea anemone benefit from the relationship. Choice (A) is incorrect because in a competitive relationship, there is a struggle between organisms to survive. Choice (C) is incorrect because a parasitic relationship involves one organism living in/on a host organism and causing it harm. This is not the case in this scenario. Choice (D) is incorrect because a predator–prey relationship is one in which one organism kills another organism for food.</p>
5	S7L4a	S7CS5a	2	D	<p>The correct answer is choice (D) Producers provide nutrients to consumers. Choices (A) and (B) are incorrect because the transfer of energy is not the transfer of matter. Choice (C) is incorrect because consumers do not provide nutrients to producers.</p>

Item	Standard/ Element	Characteristics of Science	DOK Level	Correct Answer	Explanation
6	S7L4a	S7CS5a	2	D	<p>The correct answer is choice (D) The European green crab will reduce the amount of matter transferred from the clams to the shore crab. Both the green crab and the shore crab eat clams. The green crab will compete with the shore crab for clams, thus reducing the availability of this food to the shore crab. As a predator of the shore crab, the European green crab will also reduce the overall number of shore crabs available to eat the clams. Choice (A) is incorrect because matter is not transferred to green algae. As a producer, it transfers matter to other organisms in the web. Choices (B) and (C) are incorrect because matter is not transferred from the shore crab to the clams. Instead, clams are a food source for shore crab, so matter is transferred from the clams to the shore crab.</p>
7	S7L4c	S7CS5a	2	A	<p>The correct answer is choice (A) The population will move or die out. Short-term environmental changes, such as drought, floods, or pollution, don't give populations time to adapt to change, and therefore force them to move or become extinct. Choice (B) is incorrect because the environmental change would be detrimental to the diversity of the population and would not allow for an increase in population. Choice (C) is incorrect because the development of new behaviors would not be able to offset the loss of habitat and food. Choice (D) is incorrect because the field mice could not change fur color to camouflage themselves.</p>

Item	Standard/ Element	Characteristics of Science	DOK Level	Correct Answer	Explanation
8	S7L4b	S7CS6c	2	B	<p>The correct answer is choice (B) Sun → cordgrass → snail → blue crab → alligator. Energy from the Sun is captured by plants and then passed through the food chain shown in B. Choice (A) is incorrect because the Sun is always the initial source of energy in a food chain. Choice (C) is incorrect because blue crabs do not eat terrapins; terrapins eat blue crabs. Choice (D) is incorrect because the Sun is always the initial source of energy in a food chain. In addition, alligators do not eat cordgrass.</p>
9	S7L2a	S7CS5a	2	C	<p>The correct answer is choice (C) The cell will be unable to obtain energy for cell division. Cells require nutrients to divide and reproduce. Cells also take in nutrients to perform functions such as regulating their internal environment, repairing damage, and removing wastes. Choice (A) is incorrect. Cells can recycle some waste products, but the accumulation of waste products will lead to cell death over time. Choice (B) is incorrect. Energy is required for cell division to happen, but cell division does not produce more energy. Choice (D) is incorrect because cells cannot produce the nutrients they need for energy.</p>
10	S7L2b	S7CS5a	2	B	<p>The correct answer is choice (B) Chloroplasts use energy to make glucose, and mitochondria use glucose to make energy. Choice (A) is incorrect because chloroplasts store glucose, and mitochondria make energy. Choice (C) is incorrect because only chloroplasts transform solar energy into chemical energy stored in glucose. Choice (D) is incorrect because chloroplasts make energy but do not store it in their structure.</p>

Item	Standard/ Element	Characteristics of Science	DOK Level	Correct Answer	Explanation
11	S7L2b	S7CS5a	2	B	The correct answer is choice (B) The cell would not have enough energy to function. Mitochondria supply most of a cell's energy needs. Choice (A) is incorrect because cellular division would decrease, because the mitochondria would not release energy from food to allow division to happen. Choice (C) is incorrect because the mitochondria provide energy to the cell and have no effect on tissue formation. Choice (D) is incorrect because the nucleus is not able to take over the functions of other organelles.
12	S7L2e	S7CS5a	2	D	The correct answer is choice (D) circulatory, muscular, and nervous. When the nervous system detects a decrease in the temperature of the blood, it causes the muscular system to shiver. Choices (A) and (B) are incorrect because the skeletal and immune systems are not engaged in response to temperature change. Choice (C) is incorrect because the immune and excretory systems are not engaged in response to temperature change.
13	S7L2c	S7CS5a	1	D	The correct answer is choice (D) Organs are made of different types of tissues. Organs perform specific functions within the body and are made of different types of tissues. Tissues provide specific functions and structures for organs. Choice (A) is incorrect because tissues are made up of differentiated cells. Choice (B) is incorrect because organs are made up of different types of tissues performing specific functions. Choice (C) is incorrect because organs are made of different types of tissues that contain differentiated cells.

Item	Standard/ Element	Characteristics of Science	DOK Level	Correct Answer	Explanation
14	S7L2d	S7CS5a	3	B	<p>Choice (B) is correct. The respiratory system removes wastes in the form of gases, and water and some salts are removed through the skin. Water vapor and carbon dioxide are removed through the respiratory system, while the skin primarily removes wastes in the form of water and salts. Choices (A) and (C) are incorrect because the respiratory system removes wastes from all parts of the body, and that waste may be removed through the skin. Choice (D) is incorrect because the respiratory system is primarily responsible for removing gaseous wastes.</p>
15	S7L2e	S7CS5a	2	D	<p>The correct answer is choice (D) Your nervous system responds to the sound. Your nervous system then sends a signal to your muscular system, and you jump out of your chair. When the nervous system communicates with the muscular system, the body is able to move. Choice (A) is incorrect. The immune system works to protect the body from diseases inside the body structure. The sensing of danger is a response by the nervous system, which coordinates voluntary and involuntary actions and sends signals through the body. Choice (B) is incorrect because the body would have to first sense danger. Choice (C) is incorrect because your body's first response is to sense danger and act on it. Only then will your circulatory and respiratory systems respond to the use of your muscles.</p>

Item	Standard/ Element	Characteristics of Science	DOK Level	Correct Answer	Explanation
16	S7L3b	S7CS6c	2	B	The correct answer is choice (B) asexual reproduction in the spring when offspring are needed to populate the species; sexual reproduction in the fall when offspring have time to develop. Water fleas need to reproduce as much offspring as possible in a short time in the spring to ensure the survival of its species, so they reproduce asexually. In the fall, more time is available to develop offspring, and reproducing sexually helps create genetic variation in the species. Choice (A) is incorrect because more water-flea offspring are needed in the spring, when environmental conditions are more extreme and likely to reduce the population. Choices (C) and (D) are incorrect because both forms of reproduction have advantages that benefit the water fleas, depending upon the time of year.
17	S7L3a	S7CS3d	3	C	The correct answer is choice (C) The guinea pig received a dominant gene for black coat color from one parent and a recessive gene for white coat color from the other parent. This is the only option presented that will result in a black coat. Choice (A) and (B) are both incorrect because the guinea pig received a gene for coat color from each parent. Choice (D) is incorrect because two recessive genes for coat color will result in a white coat, not black.

Item	Standard/ Element	Characteristics of Science	DOK Level	Correct Answer	Explanation
18	S7L3c	S7CS3d	2	D	<p>The correct answer is choice (D) Plant 2 and Plant 4. Plant 2 provides genes for fewer seeds and Plant 4 provides genes for high sugar content and does not grow best in dry climates, suggesting that it would grow better in the humid climate of Georgia. Choice (A) is incorrect because both plants chosen have genes that allow them to grow best in dry climates, which are not found in Georgia. Choice (B) is incorrect because neither plant provides genes for high sugar content. Choice (C) is incorrect because neither plant provides genes for the lowest number of seeds possible.</p>
19	S7L3c	S7CS3d	3	B	<p>The correct answer is choice (B) Mare A should be bred for endurance, and Mare B should be bred for speed. Offspring A ran slower initial miles, but ran faster than Offspring B over a longer distance. Choice (A) is incorrect because Offspring A ran slower times than Offspring B, and Offspring B got slower over distance. Choices (C) and (D) are incorrect. The data show that the offspring of Mare A are more likely to handle endurance work, and the offspring of Mare B are likely to be faster.</p>

Item	Standard/ Element	Characteristics of Science	DOK Level	Correct Answer	Explanation
20	S7L5b	S7CS5a	2	C	<p>The correct answer is choice (C) Members of a species with traits that allow them to survive and reproduce in an environment will increase in population, while those without those traits will die. Eventually, unsuitable traits will disappear from a species. This is how natural selection affects species. Choice (A) is incorrect because fur color will change only if it is an unsuitable trait for the environment and affects the organism's survival and/or reproduction. Choice (D) is incorrect because larger organisms do not always have better survival chances, compared with smaller organisms. Choice (B) is incorrect because there are more factors that affect populations of predators and prey than natural selection alone.</p>
21	S7L5b	S7CS5a	3	B	<p>The correct answer is choice (B) Walking catfish with large pectoral fins are more likely to survive a trip to distant areas of water. The population is likely to evolve to have larger pectoral fins. Larger pectoral fins are an individual characteristic that make it more likely that a walking catfish will survive a trip to a distant body of water. Natural selection will favor the catfish with larger pectoral fins, as more of them survive. Choice (A) is incorrect because smaller pectoral fins make it less likely for the walking catfish to survive the trip to a distant body of water. Choice (C) is incorrect. A walking catfish with larger pectoral fins is more likely to travel farther to get to a distant body of water. Choice (D) is incorrect. A catfish with larger pectoral fins has an individual characteristic that makes it more likely to survive a trip to a distant body of water.</p>

Item	Standard/ Element	Characteristics of Science	DOK Level	Correct Answer	Explanation
22	S7L5c	S7CS6c	3	C	<p>The correct answer is choice (C) The species in Layer C may have evolved from the species in Layer B. These fossils demonstrate gradualism, the theory that states that species gradually change over time. Because the fossils are found in different layers of sedimentary rock, the newer layer contains species that may have evolved from older species found in the older layer below it. Choice (A) is incorrect because being in adjacent layers does not provide enough information to indicate that they are different species. Choice (B) is incorrect because there is not enough information about the fossils to know whether they are the same. Choice (D) is incorrect because fossils found in lower layers of sedimentary stone are usually older than the fossils found in upper layers.</p>
23	S7L5c	S7CS7c	2	B	<p>The correct answer is choice (B) The claim is reasonable because fossils are records of things that lived long ago. Since the fossil and the plant share similar features, it can be assumed that the species that formed the fossil has not changed greatly over time. Choice (A) is incorrect because the plant has changed over time but not greatly. Choice (C) is incorrect because the claim is reasonable, the plant has changed over time, just not much. Choice (D) is incorrect because the claim is reasonable, the fossil appears to belong to a species that lived long ago.</p>

Item	Standard/ Element	Characteristics of Science	DOK Level	Correct Answer	Explanation
24	S7L5a	S7CS5a	3	A	The correct answer is choice (A) Over time, fence lizards with longer legs were more likely to survive and passed this trait on to offspring. Choice (B) is incorrect because leg stretching is not an inherited trait and would not be passed on to offspring. Choice (C) is incorrect because trying to avoid stepping on ants would not cause the lizards' legs to grow longer. Choice (D) is incorrect because the venom did not directly play a role in the change in leg length.

ACTIVITY

The following activity develops skills in Unit 3: Structure and Function of Cells.

Standard: S7L2

Nutrient Uptake in Cells

Duration: 1 week

Materials:

- Two eggs
 - Two plastic cups
 - Water
 - Sugar
 - Scale
-
- Dissolve the eggshells from the eggs by placing the eggs in vinegar to decalcify the shell and expose the membrane that lines the inside of the shell. After three days, the shells will be dissolved and the egg will be covered by the soft inner membrane alone.

Procedure:

1. Determine the mass of each egg and record the results.

	Starting Mass (g)	Appearance	Final Mass (g)	Appearance
Egg A				
Egg B				

2. Carefully place one egg in a cup and fill the cup with water. Mark the cup “Egg A.”
3. Fill the second cup with water. Add 10 grams of sugar and stir. Place the other egg in the sugar solution you just created. Mark the cup “Egg B.”
4. Place the cups in a safe area and return to them the next day.
5. After a day, remove each egg from the cup and determine the mass of the egg. Record any changes in appearance you may note.

Research the following questions after the activity:

- *How did each egg change in the solution?*
- *Which egg would be more representative of a healthy cell? Explain your reasoning.*
- *What would happen to a cell if it received too much of a nutrient?*
- *Can you explain these results in terms of diffusion and osmosis?*

ACTIVITY

The following activity develops skills in Unit 6: Evidence of Evolution.

Standard: S7L5

Survival and Coat Color

Work with 3 friends or family members if possible.

Materials:

- One large piece of white construction paper
- One large piece of brown construction paper
- Two data tables (use tables on page 164)
- Twenty-five small squares cut from white construction paper (gene cards)
- Twenty-five small squares cut from brown construction paper (gene cards)
- Five cards that say SURVIVES (incident cards)
- One card that says DISEASE (incident card)
- One card that says PREDATOR (incident card)
- Eighteen cards that say CONTRASTS (incident cards)

Procedure:

1. Mix up the 25 white and 25 brown construction-paper pieces (gene cards) and set them aside.
2. Mix up the incident cards and stack them in a pile.
3. The brown and white gene cards represent genes that a fox will inherit from its parents for coat color. Draw two gene cards to simulate an offspring receiving one coat-color gene from its father and one coat-color gene from its mother. This creates the color of one new fox. Lay the two gene cards on the white construction paper, which represents a snowy environment. The white coat color is dominant. If you draw a brown and a white card, your fox is **white**; if you draw two white cards, your fox is **white**; but if you draw two brown cards, your fox is **brown**. Record the new fox's color in the snow-environment data table under "Births," with a tally mark.
4. Next, draw an incident card to indicate what will happen to this fox.
 - a. If you draw the card that says SURVIVES, the fox lives. Place the two gene cards in a "living" pile. Place the incident card at the bottom of the incident pile.
 - b. If you draw the card that says DISEASE, the fox dies of a disease. Place the two gene cards in a "dead" pile. The incident card goes to the bottom of the incident pile. Record the death in the data table under "Deaths," with a tally mark.
 - c. If you draw the card that says PREDATOR, the fox dies from a predator. Place the two gene cards in the "dead" pile. The incident card goes to the bottom of the incident pile. Record the death in the data table under "Deaths," with a tally mark.

- d. If you draw the card that says CONTRASTS, the fox lives if it does **not** contrast with its environment. For the snowy environment, if the fox is **white**, it survives. Place the two gene cards in the “live” pile and the incident card at the bottom of the incident pile. If the fox is **brown**, it contrasts with its environment. Therefore, it will die. Place the two gene cards in the “dead” pile, and the incident card at the bottom of the incident pile. Record the death in the data table under “Deaths,” with a tally mark.
5. Repeat these steps until there are no more gene cards.

Generation 2

6. Take the live pile and mix up the gene cards. Mix up the incident cards. Ignore the dead pile for now.
7. Repeat Steps 3 and 4 for Generation 2. Create new live and new dead piles and record the births and deaths in the Generation 2 row on your data chart.

Generation 3

8. Repeat again for Generation 3.

Forest Environment

9. Now replace the white construction paper with the brown construction paper, which represents a forest environment. Look at the second data table, labelled “Forest Environment.” Gather all the gene cards together (both the live and dead piles) and mix them up. Place all incident cards together and mix them up. In the forest environment, the brown-coat gene is dominant. Draw two gene cards. If you draw a brown and a white card, your fox is brown; if you draw two white cards, your fox is white; but if you draw two brown cards, your fox is brown. Record the inherited coat color in the data table under “Births,” with a tally mark.
10. Play the game as before. If you draw the card that says CONTRASTS, the fox lives if it does **not** contrast with its environment. Now that the fox is in a forest environment, if it is **brown**, it survives—place the two gene cards in the live pile and the incident card at the bottom of the incident pile. If the fox is **white**, it contrasts with its environment. Therefore, it will die. Place the two gene cards in the dead pile and the incident card at the bottom of the incident pile. Record the death in the data table under “Deaths,” with a tally mark.
11. Continue with Generations 2 and 3, as in the snow-environment simulation.

Data Tables

Snow Environment	Births		Deaths	
	White Fox	Brown Fox	White Fox	Brown Fox
1				
2				
3				

Forest Environment	Births		Deaths	
	White Fox	Brown Fox	White Fox	Brown Fox
1				
2				
3				

Research the following questions after the activity:

- *How did the environment affect the group over time?*
- *How did this activity model natural selection?*

SOCIAL STUDIES

DESCRIPTION OF TEST FORMAT AND ORGANIZATION

The Grade 7 Social Studies EOG assessment has a total of 75 selected-response (multiple-choice) items.

The test will be given in two sections.

- You may have up to 70 minutes per section to complete Sections 1 and 2.
- You will have about 90 to 140 minutes for the complete Social Studies EOG assessment.

CONTENT

The Grade 7 Social Studies EOG assessment will measure the Grade 7 Social Studies standards that are described at www.georgiastandards.org.

The content of the assessment is organized into four groups, or domains.

- History
- Geography
- Government and Civics
- Economics

ITEM TYPES

The Social Studies portion of the Grade 7 EOG assessment consists of selected-response (multiple-choice) items only.

SOCIAL STUDIES DEPTH OF KNOWLEDGE EXAMPLE ITEMS

Example items that represent applicable DOK levels of the Social Studies assessment are provided on the following pages. The items and explanations of what is expected of you to answer them will help you prepare for the test.

All example and sample items contained in this guide are the property of the Georgia Department of Education.

Example Item 1

DOK Level 1: This is a DOK level 1 item because it requires the student to recall information.

Social Studies Grade 7 Content Domain: Geography

Standard: SS7G2. The student will discuss environmental issues across the continent of Africa. c. Explain the impact of desertification on the environment of Africa from the Sahel to the rainforest.

What is desertification?

- A. the depletion of desert resources
- B. the reduction of oases in the desert
- C. the expansion of the desert into former grassland areas
- D. the migration of people to the desert from the rainforests

Correct Answer: C

Explanation of Correct Answer: The correct answer is choice (C) the expansion of the desert into former grassland areas. Choices (A), (B), and (D) are not correct because they are not the definition of desertification.

Example Item 2

DOK Level 2: This is a DOK Level 2 item because it requires reasoning and comparing.

Social Studies Grade 7 Content Domain: Geography

Standard: SS7G4. The student will describe the diverse cultures of the people who live in Africa. a. Explain the differences between an ethnic group and a religious group.

Which of these is an example of a religious group?

- A. Zulu dancers practice with their troop.
- B. Ashanti weavers make kente cloth for festivals.
- C. Muslim men fast during the month of Ramadan.
- D. Swahili women teach their children to make traditional food.

Correct Answer: C

Explanation of Correct Answer: The correct answer is choice (C) Muslim men fast during the month of Ramadan. Someone who is Muslim is a follower of the faith of Islam. Choices (A), (B), and (D) are all incorrect because they are examples of ethnic groups, not religious groups.

Example Item 3

DOK Level 3: This is a DOK Level 3 item because it requires analysis of the maps and integrating information.

Social Studies Grade 7 Content Domain: Geography

Standard: SS7G3. The student will explain the impact of location, climate, and physical characteristics on population distribution in Africa. a. Explain how the characteristics in the Sahara, Sahel, savanna, and tropical rainforests affect where people live, the type of work they do, and how they travel.

Look at the maps.

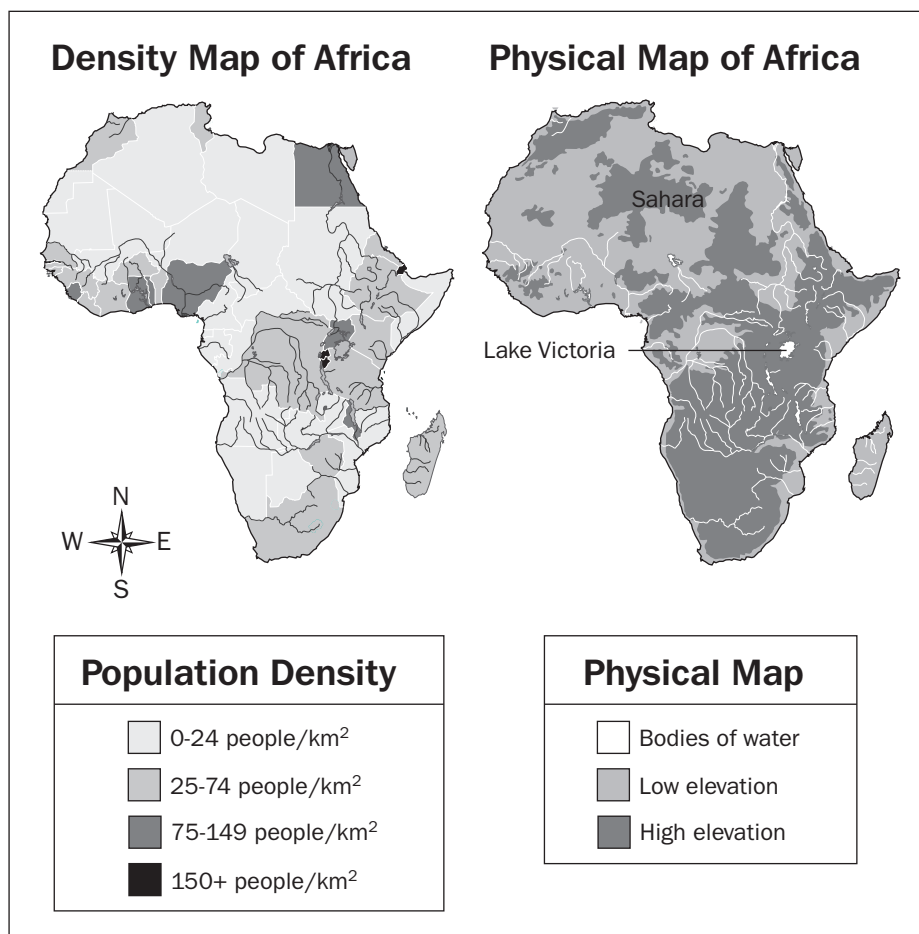

Which conclusion can be drawn from looking at the maps?

- A. The Sahara has a high population density.
- B. Central Africa has a low population density.
- C. Areas of low elevation have the lowest population density.
- D. Areas near bodies of water have the highest population density.

Correct Answer: D

Explanation of Correct Answer: The correct answer is choice (D) Areas near bodies of water have the highest population density. This is true of bodies of water such as the oceans, Lake Victoria, and the major rivers. Choice (A) is incorrect because the Sahara has the lowest population density. Choice (B) is incorrect because Central Africa contains some pockets of the highest population density on the continent. Choice (C) is incorrect because some areas of low elevation have high population densities.

SOCIAL STUDIES CONTENT DESCRIPTION AND ADDITIONAL SAMPLE ITEMS

In this section, you will find information about what to study in order to prepare for the Grade 7 Social Studies EOG assessment. This includes key terms and important vocabulary words. This section also contains practice questions, with an explanation of the correct answers, and activities that you can do with your classmates or family to prepare for the assessment.

The organization of Social Studies units in this guide is based on Frameworks developed by the Curriculum and Instruction Division of the Georgia Department of Education. Unit 1 focuses on over-arching themes and concepts, rather than specific standards. Unit 1 will, therefore, not be a part of the End-of-Grade assessment. The Social Studies section begins with Unit 2. These Frameworks can be accessed at <https://www.georgiastandards.org/Frameworks/Pages/BrowseFrameworks/socialstudies6-8.aspx>.

All example and sample items contained in this guide are the property of the Georgia Department of Education.

CONTENT DESCRIPTION

The four domains (History, Geography, Government/Civics, and Economics) are fully integrated.

Some of the topics you will study in this guide are the following:

- The world outside of the United States
- The cultures, geographies, governments, economics, and histories of Africa, Southwest Asia (Middle East), and Southern and Eastern Asia
- The correlation between human and physical geography of each region
- Reasons for population distribution in each region and the effect of geography on culture
- Types of governments that are different from the United States
- How governments distribute power and how citizens participate in the political process
- Economies of each region and their effectiveness in relation to the standard of living
- Effectiveness of investments in human capital and capital goods
- Events of each region's past, up until the present

Unit 2: Southwest Asia (Middle East) Today

In this unit, you will examine Southwest Asia (Middle East) today. You will learn about the countries that inhabit this area: Afghanistan, Iraq, Iran, Israel, Turkey, and Saudi Arabia. You will learn about important issues that affect these countries, such as religious differences and intolerance. You will look at the geography of this area, including deserts, the Arabian and Red Seas, the Persian Gulf, and the Suez Canal.

Southwest Asia

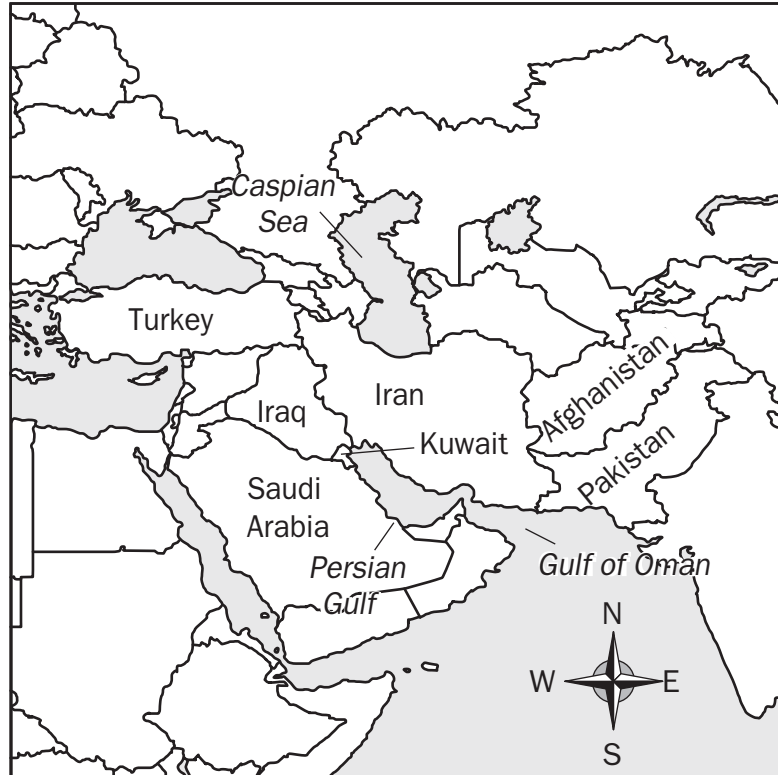

KEY TERMS

Abrahamic religions: The religions that share a common origin that can be traced back to Abraham in the Bible. These religions include Christianity, Judaism, and Islam. (G8c)

Afghanistan: A nation in southwest Asia that is landlocked and predominantly Islamic. (G5b)

Afghanistan and Iraq Wars: After the terrorist attacks on the United States in 2001, which destroyed the World Trade Center towers in New York City and resulted in the deaths of nearly 3,000 people, the United States invaded Afghanistan. The nation's government was sheltering Al Qaeda, the group thought responsible for the attacks. In 2003, the U.S. government and several of its allies invaded Iraq, asserting that the nation was a threat to the free world. (H2d)

Anti-Semitism: Discrimination against or hatred for people of Jewish heritage, ethnicity, or belief. (H2b)

Arabian Sea: An important trade route in the northwestern part of the Indian Ocean, between Arabia and India. (G5a)

Christianity: A collection of religious beliefs based on the teachings of Jesus of Nazareth. There is a belief in one god, known as monotheism, and both the Old and New Testaments are perceived as divinely inspired. It is considered an Abrahamic religion, as are Judaism and Islam, meaning they share a common origin that can be traced back to Abraham in the Bible. (G8c)

Desert: A usually dry area of land, hot during the day and cold at night, with little vegetation. Much of the Middle East consists of desert areas with sparse population. (G7b)

Ethnic group: A group of people of common descent or who share a cultural background. (G8a, G4a)

Euphrates River: A river in Southwest Asia that flows from Turkey through Syria and Iraq into the Persian Gulf. Because the river is an important trade route, populations have grown up around it, with industry centered on that trade. (G5a, G7b)

Gaza Strip: A disputed strip of land along the southeastern shore of the Mediterranean Sea. It is currently under the authority of Palestine, though occupied by Israel. (G5a)

Holocaust: The murder of Jewish men, women, and children committed by Germany's Nazis during World War II. Six million Jews lost their lives, along with tens of thousands of members of other persecuted groups. (H2b)

Iran: A predominantly Shia Muslim nation in southwestern Asia. (G5b)

Iraq: A nation in western Asia in which most people practice Islam. (G5b)

Islam: A religion based on the teachings of the prophet Muhammad. It is monotheistic and recognizes various biblical figures, including Moses and Jesus, as prophets. It is considered an Abrahamic religion, as are Judaism and Christianity, meaning they share a common origin that can be traced back to Abraham in the Bible. (G8c)

Israel: A nation in Southwest Asia established in 1948 as a home for people of Jewish descent. The land area was chosen by European powers because of the Jewish people's historical connection to it. (H2b, G5b)

Jordan River: A river in Southwest Asia that flows south through Syria and Lebanon and along the border of Israel and Jordan. Because the river is an important trade route, populations have grown up around it, with industry centered on that trade. (G5a, G7b)

Judaism: A collection of religious beliefs based on the teachings in the Torah. There is a belief in one god, and it recognizes the prophets of the Old Testament. It is considered an Abrahamic religion, as are Christianity and Islam, meaning they share a common origin that can be traced back to Abraham in the Bible. (G8)

Literacy rates in the Middle East: Though literacy rates doubled in the Middle East between 1960 and 1995, they remain low. They continue to be higher in urban areas than they are in rural areas, and people who are able to read tend to have better jobs and a higher standard of living than those who cannot. (G8e, G4c)

Monarchy: A system of government in which a king or queen acts as the head of state. Saudi Arabia is an absolute monarchy, with members of the Royal Saudi family in control of most political institutions and functions. The king acts as the Chief of State and the head of the government. (CG5a)

Monotheism: Religions that believe there is only one god. (G8c)

Oil: A black, thick, and combustible liquid used in the making of gasoline and lubricants. Its discovery in Southwest Asia has had a huge impact on the Middle East, resulting in large corporate investments from outside the region. The amount of Middle Eastern oil on the world market continually changes, causing increases and decreases in gasoline prices worldwide. Due to the influx of oil profits in the region, there has been a steady rise in literacy rates and the standard of living among Middle Easterners. (G7a)

Ottoman Empire: An imperialistic Turkish empire founded by Osman I in 1300. It lasted until the end of World War I. It dominated the area and included most of southeastern Europe, the Middle East, and North Africa. Its capital was Constantinople. (H2b)

Parliamentary system of government: A democratic form of government in which voters choose representatives of a governing body called a parliament. The government of Israel is a parliamentary democracy. (CG5a)

Persian Gulf: Part of the Arabian Sea located between southwest Iran and the Arabian Peninsula. Home to large oil deposits, it has also been considered an important trade route. (H2d, G5a)

Persian Gulf conflict: When Iraq invaded the sovereign nation of Kuwait in 1990, the United States led a coalition of nations to end Iraqi occupation of that nation. The action was named Operation Desert Shield and lasted from August of 1990 until January of 1991. It ended with the removal of Iraq from Kuwait and a severe weakening of Saddam Hussein's Iraqi government. (H2d)

Presidential system of government: A republican form of government in which voters choose a president to lead the executive branch of government, which is separate from other branches. (CG5a)

President: The leader of a federal government, elected by a nation's citizens. A president can also be the leader of a unitary state or centralized government. (CG4c)

Prime minister: The leader of a parliamentary government. Prime ministers are chosen by members of parliament, who in turn are elected by citizens. (CG4c, CG5a)

Red Sea: An important trade route linking northeast Africa with the Arabian Peninsula. Various waterways also connect it to the Mediterranean and the Arabian Seas. (G5a)

Religion in the Middle East: There are a number of religions in the Middle East. Most people, including Arabs, Persians, and Kurds, subscribe to some form of Islamic belief. Lesser numbers practice Christianity and Judaism. (G8b)

Religious group: A group of people who share a particular belief system centered on a god or group of gods. (G8a)

Saudi Arabia: A nation in Southwest Asia that occupies the vast majority (approximately 80%) of the Arabian Peninsula. It is an Islamic monarchy run by the Saudi family. (G5b)

Shia Muslims: One of the two major branches of Islam. It is practiced mostly in Iran and recognizes only one of four Sunni caliphs, Ali, as a successor to Muhammad. (G8d)

Strait of Hormuz: An important waterway linking the Persian Gulf with the Gulf of Oman. (G5a)

Suez Canal: A man-made canal through the Isthmus of Suez in northeastern Egypt, connecting the Mediterranean and Red Seas. (G5a)

Sunni Muslims: One of the two major branches of Islam. It is practiced throughout the Middle East and lower Asia and recognizes four caliphs as successors to Muhammad. (G8d)

Theocratic system of government: A system in which leadership and rule of law are based on the religious beliefs of the people, usually the majority. Iran is an Islamic theocracy based on Shia beliefs. (CG5a)

Tigris River: A river in Southwest Asia that flows from Turkey into Iraq, where it joins with the Euphrates River. It is approximately 1,150 miles long. Because the river is an important trade route, populations have grown up around it, with industry centered on that trade. (G5a, G7b)

Turkey: A mostly Islamic country located in western Asia and southeastern Europe. (G5b)

Zionism: An international movement originally intended to establish a Jewish homeland in Palestine. Today it exists to support the interests of the nation of Israel. (H2b)

KEY IDEA

Europe Partitions the Middle East

Following the collapse of the Ottoman Empire during World War I, the League of Nations granted control over Palestine and Mesopotamia to Great Britain, while Syria and Lebanon were handed over to France. Eventually, these areas were divided into several new states, including Iraq, Jordan, and Saudi Arabia. However, European powers failed to fully consider religious, political, and historical differences among the groups living in those areas. Divisions of land between competing groups led to regional conflicts.

Today, disputes continue between Israel and Palestine, Pakistan and India, and Iraq and Iran, among other groups. (H2b, c)

Sample Items 1–2

Item 1

Which of these characteristics is shared among the three major religions of Southwest Asia?

- A. All worship one god.
- B. All forbid the eating of pork.
- C. All consider Jesus a prophet.
- D. All require pilgrimages to Mecca.

Item 2

Look at the map.



Which of these is indicated by the arrow on this map?

- A. Gaza Strip
- B. Jordan River
- C. Strait of Hormuz
- D. Suez Canal

Unit 3: Impact of Environment and Economy on Southwest Asia (Middle East)

In this unit, you will look at the economy of Southwest Asia (Middle East). You will also study the impact of the environment on this area. You will learn about Organization of the Petroleum Exporting Countries (OPEC) and the importance of oil to this region. You will locate the Euphrates River and the Tigris River and learn why they are important trade routes.

KEY TERMS

Capital: The property (buildings, machinery, etc.) and technology that represent the economic investments of a person or business. (E7b)

Command economy: An economic system in which what is produced, how it is produced, and for whom it is produced is determined by the government. (E5a, c)

Desert: A usually dry area of land, hot during the day and cold at night, with little vegetation. Much of the Middle East consists of desert, with sparse population. (G7b)

Embargo: An official ban, usually on trade with another country. Sometimes the ban is on specific goods. (E6b)

Entrepreneurship: The process of starting an organization or business. The economies of many countries are supported by small businesses begun by entrepreneurs. (E7d)

Euphrates River: A river in Southwest Asia that flows from Turkey through Syria and Iraq into the Persian Gulf. Because the river is an important trade route, populations have grown up around it, with industry centered on that trade. (G5a, G7b)

Human capital: The human knowledge, creativity, and habits that contribute to an economy. (E7a)

Irrigation: The movement of freshwater from rivers via canals into cities and farmland. Irrigation has resulted in a shortage of drinking water in some areas. (G6a)

Jordan River: A river in Southwest Asia that flows through Syria and Lebanon and south along the borders of Israel and Jordan. Because the river is an important trade route, populations have grown up around it, with industry centered on that trade. (G7b)

Market economy: An economic system in which what is produced, how it is produced, and for whom it is produced is based on supply and demand. Producers set the prices for their goods based on what individuals are willing to pay. (E5a)

Mixed economy: An economy that is part market economy and part command economy. Most countries have mixed economies. (E5b)

Oil: A black, thick, and combustible liquid used in the making of gasoline and lubricants. Its discovery in Southwest Asia has had a huge impact on the Middle East, resulting in large corporate investment from outside the region. The amount of Middle Eastern oil on the world market is continually adjusted, causing increases and decreases in gasoline prices worldwide. Due to the influx of oil profits in the region, there has been a steady rise in literacy rates and the standard of living among Middle Easterners. (G7a, E7c)

Organization of the Petroleum Exporting Countries (OPEC): An organization made up of the world's leading oil-exporting countries. Founded in 1960, its purpose is to regulate the supply of oil to consumers, thus insuring a steady supply, as well as steady profits for its producers. (E6c)

Quota: A limit set on the production of a product. Quotas can be set by governments or industry groups, such as OPEC. Its purpose is to protect domestic production and control the price of a product. (E6b)

Specialization: The focusing of a business or country on one or a relatively small number of products or services. Because most areas can produce only a limited number of goods or services, they must then trade these goods and services for others that they need. (E6a)

Tariff: A tax or duty that must be paid on a specific import or export. Tariffs are often used by governments to limit imports from other countries. (E6b)

Tigris River: A river in Southwest Asia that flows from Turkey into Iraq, where it joins with the Euphrates River. Because the river is an important trade route, populations have grown around it, with industry centered on that trade. (G5a, G7b)

Trade: The buying and selling of goods and services between nations. Trade benefits populations in the Middle East by supplying them with goods they cannot produce on their own, such as many types of food. (E6d)

Traditional economy: An economic system in which what is produced, how it is produced, and for whom it is produced is based on the traditions, beliefs, and customs of society. Traditional economies are usually agriculturally based. (E5a)

Voluntary trade: An economic market in which individuals and businesses are allowed to buy from and sell to whom they choose. A benefit of such an exchange is that most parties gain something they want from it. (E6a)

Water pollution: The contamination of water by harmful chemical compounds, usually as a result of industrial activity. Due to a lack of regulation, water pollution is a serious problem in parts of the Middle East where, as with irrigation, it has resulted in a shortage of drinkable water for large portions of the population. (G6a)

Sample Items 3–4

Item 3

Read the information in the chart.

Country	Production of Oil	GDP per Capita
Saudi Arabia	11,730,000 barrels per day	\$31,300
United Arab Emirates	2,142,000 barrels per day	\$29,900
Yemen	156,500 barrels per day	\$2,500

Which conclusion can **BEST** be drawn from the information in this chart?

- A. Saudi Arabia's GDP per capita is the highest in Southwest Asia.
- B. Saudi Arabia's GDP per capita is the result of its high production of oil.
- C. More barrels of oil are produced in Yemen than in the United Arab Emirates.
- D. More people are employed in Saudi Arabia than in the United Arab Emirates.

Item 4

Which of these is a purpose of Organization of the Petroleum Exporting Countries (OPEC)?

- A. to control the price of oil
- B. to promote education for all citizens
- C. to lower tariffs for Southwest Asian products
- D. to prevent conflict between Southwest Asian countries

Unit 4: Origins of Modern Southwest Asia (Middle East)

In this unit, you will take a closer look at the different religions in modern Southwest Asia, and how some countries are impacted by their religious beliefs. You will learn about Christianity, Judaism, and Islamic religious groups.

Middle East

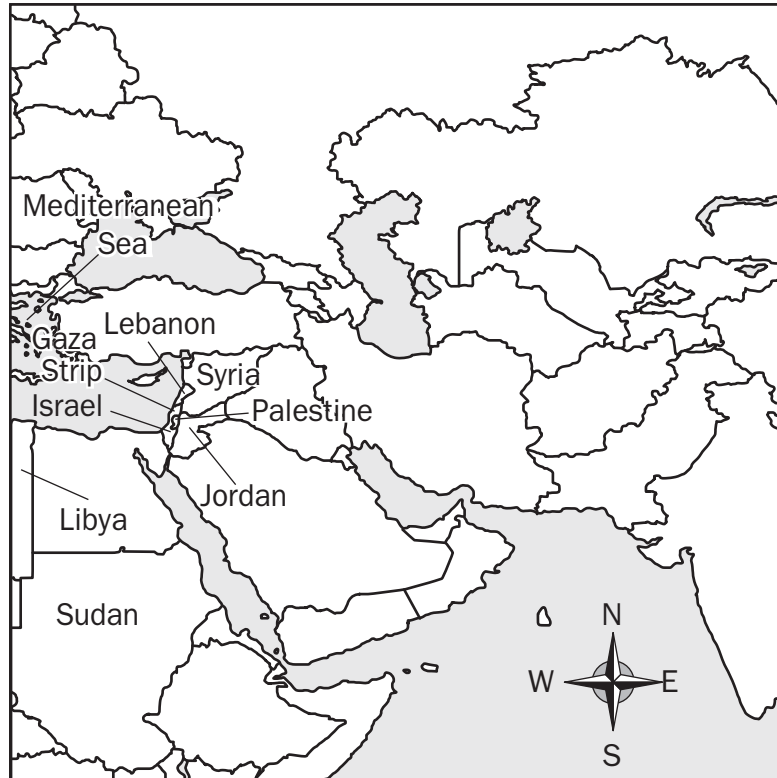

KEY TERMS

Christianity: A collection of religious beliefs based on the teachings of Jesus of Nazareth. There is a belief in one god, known as monotheism, and both the Old and New Testaments are perceived as divinely inspired. It is considered an Abrahamic religion, as are Judaism and Islam, meaning they share a common origin that can be traced back to Abraham in the Bible. (G8c)

Ethnic group: A group of people of common descent or who share a cultural background. (G8a)

European partitioning: Following the collapse of the Ottoman Empire after World War I, the League of Nations divided control of the Middle East between various European nations. Over the next several decades, these nations created new states and set new boundaries for old ones without taking into consideration pre-existing conflicts. Those conflicts exist to this day. Many of these conflicts center on land disputes (Israel and Iran) and religion (Iran and Iraq). (H2a, c)

Islam: A collection of religious beliefs based on the teachings of Muhammad. It is monotheistic and recognizes various biblical figures, including Moses and Jesus, as prophets. It is considered an Abrahamic religion, as are Judaism and Christianity, meaning they share a common origin that can be traced back to Abraham in the Bible. (G8c)

Israel: A nation in Southwest Asia established in 1948 as a home for people of Jewish descent. The land area was chosen by European powers because of the Jewish people's historical connection to it. (H2b, G5b)

Judaism: A collection of religious beliefs based on the teachings in the Torah. There is a belief in one god, and it recognizes the prophets of the Old Testament. It is considered an Abrahamic religion, as are Christianity and Islam, meaning they share a common origin that can be traced back to Abraham in the Bible. (G8)

Persian Gulf conflict: When Iraq invaded the sovereign nation of Kuwait in 1990, the United States led a coalition of nations to end Iraqi occupation of that nation. The action was named Operation Desert Shield and lasted from August of 1990 until January of 1991. It ended with the removal of Iraq from Kuwait and a severe weakening of Saddam Hussein's Iraqi government. (H2d)

Religion in the Middle East: There are a number of religions in the Middle East. Most people, including Arabs, Persians, and Kurds, subscribe to some form of Islamic belief. Lesser numbers practice Christianity and Judaism. (G8b)

Religious group: A group of people who share a particular belief system centered on a god or group of gods. (G8a)

Sample Items 5–6

Item 5

Which event led to the establishment of the state of Israel?

- A. the Holocaust
- B. the end of apartheid
- C. the Persian Gulf conflict
- D. the breakup of the Ottoman Empire

Item 6

Why is religion a continuing source of conflict in Southwest Asia?

- A. The area contains holy sites for three of the world's major religions.
- B. One religious group controls the major natural resources of the area.
- C. People from each religion in the area speak a different language, leading to mistrust.
- D. Each country in the area has its own local religion, leading to conflicts between nations.

Unit 5: Southern and Eastern Asia Today

In this unit, you will learn about different systems of government and political systems in Southern and Eastern Asia today. You will continue to look at different religions. You will examine the effect climate and geography have on this area.

Southern and Eastern Asia

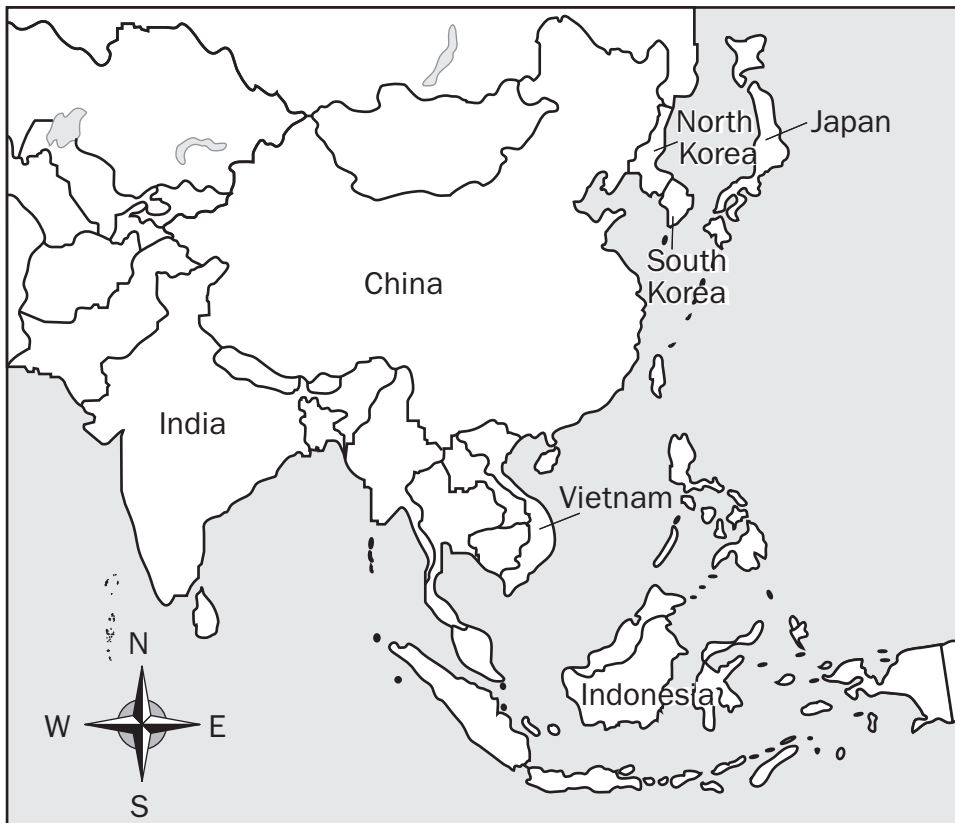

KEY TERMS

Autocracy: A system in which all of the power is held by one person. In this system of government, the ruler has absolute or unlimited power. (CG6B)

Bay of Bengal: The portion of the Indian Ocean located east of India. (G9a)

Buddhism: A religious belief system based on the spiritual teachings of Buddha. Centering on the idea of reincarnation, it teaches that people can find true enlightenment by ending desire, which is the cause of suffering. It originated in India and spread throughout Southeastern and Eastern Asia. (G12b)

China: The third largest country in terms of area in the world and the most populous. It is located in Asia. (G9b)

Climate of Asia: Asia has a diverse climate. The southeast section tends to be wet and tropical. The southern and eastern sections are dominated by monsoons. The north (Siberia) is extremely cold, while the south is very hot. Siberia and the deserts of China and Mongolia tend to be sparsely inhabited, while sections located along large bodies of water tend to be more heavily populated. (G11a)

Communism: A social and political system in which means of production are thought to be owned by the people as a whole rather than by individuals. In reality, a person or group of people actually control the means of production. China is a communist nation. (CG7a)

Confederation: A group of largely independent states or nations that grant limited authority to a central government. (CG6a)

Confucianism: The philosophical teachings of Confucius centered on ethical living. (G12b)

Constitutional monarchy: A system of government in which a king or queen acts as the head of state, though laws are enacted by a parliament elected by voters. Japan is a constitutional monarchy. (CG7a)

Democracy: A system of government in which a nation's citizens vote for their leaders. (CG1b)

Federal system of government: A system in which individual states share authority with a central government. (CG6a, CG7a)

Ganges River: A river in Asia that begins in the Himalayan Mountains, runs across India, and empties into the Bay of Bengal. It is considered sacred to believers in Hinduism. A large population has grown up around the Ganges River. (G9a, G11b)

Gobi Desert: A large, sparsely populated desert in central China. (G9a, G11b)

Himalayan Mountains: The tallest mountain chain in the world. Located in south-central Asia, it stretches into the nations of Kashmir, India, Tibet, Nepal, and Bhutan. The region is cold and has little vegetation, making it difficult to inhabit. (G9a, G11b)

Hinduism: The primary religion of India. Based on the idea of reincarnation, it teaches that people can dictate how they are reborn by how they live at present. There is also a belief in more than one god. (G12b)

Huang He (Yellow River): A river in northern China that begins in the Kunlun Mountains, flows approximately 3,350 miles east, and empties into the Bohai Sea. It is named after the yellow silt it carries. (G9a)

India: The largest country situated on a peninsular subcontinent that extends into the Indian Ocean. (G9b)

Indian Ocean: A large body of water that extends from Asia in the north to Antarctica in the south and from Africa in the west to Australia in the east. (G9a)

Indonesia: A country in Southeast Asia. Located in the Malay Archipelago, it consists of several islands, including Java and Sumatra. It is home to the world's largest Muslim population. (G9b)

Indus River: A river that begins in Tibet and flows through Kashmir and Pakistan into the Arabian Sea. (G9a)

Islam: A collection of religious beliefs based on the teachings of Muhammad. It is monotheistic and recognizes various biblical figures, including Moses and Jesus, as prophets. It is considered an Abrahamic religion, as are Judaism and Christianity, which means it can trace its roots back to Abraham in the Bible. (G12b)

Japan: An archipelago/country located off the eastern coast of China, in the Pacific Ocean. (G9b)

Korean Peninsula: The peninsula in Asia that separates the Yellow Sea from the Sea of Japan. (G9a)

Literacy rates in Asia: The rates at which people can read is diverse across Asia. In parts of China and western Asia, literacy is low, while in Japan and other parts of Eastern Asia it tends to be much higher. In those areas where it is highest (Japan), the standard of living is also higher. As with other parts of the world, urban areas have higher literacy rates than rural areas. (G12c)

Mekong River: A river in southern Vietnam that empties into the South China Sea. (G9a)

Natural resources of Asia: Many parts of China, Indonesia, and Malaysia are heavily forested. In these regions, timber is a major resource. Fishing and agriculture are also major industries in Southern and Eastern Asia. In parts of Eastern Asia, particularly in China, mining is also an important industry. (G11a)

North Korea: A nation in Asia located on the Korean Peninsula. Its current boundary with South Korea was established at the end of the Korean War (1950–1953). (G9b)

Oligarchy: A system in which a small and powerful group controls the government. (CG6b)

Parliamentary system of government: A democratic form of government in which voters choose representatives to a governing body called a parliament. (CG6c)

Presidential system of government: A republican form of government in which voters choose a president to lead the executive branch of government, which is separate from other branches. (CG6c)

Sea of Japan: A sea in the Pacific Ocean that separates China from Japan. (G9a)

Shintoism: The largest religion in Japan. Its believers worship gods in the form of Earth's natural forces and believe that the emperor is a human descendant of the sun goddess. (G12b)

South Korea: A nation in Asia located on the southern end of the Korean Peninsula. Its current boundary with North Korea was established after the Korean War (1950–1953). (G9b)

Taklimakan Desert: A desert located in western China. (G9a)

Unitary system of government: A system in which an entire country is ruled by a single government. Power is not shared with smaller states as it is in a federal system. (CG6a)

Vietnam: A nation in Southeast Asia located along the South China Sea. For many years it was divided into North and South Vietnam. When North Vietnam attempted to overthrow the South Vietnamese government, the United States entered the conflict, which became known as the Vietnam War. When South Vietnam collapsed in 1975, the two countries were reunited. (G9b)

Yangtze (Chang Jiang) River: Flowing east from Tibet into the East China Sea, it is the longest river in Asia. (G9a)

Yellow Sea: The part of the Pacific Ocean that separates China from the Korean Peninsula. (G9a)

KEY IDEA

Ethnic and Religious Groups in the Middle East

An ethnic group consists of people of common descent or people who share a cultural background. A religious group consists of people who share an organized system of belief centered on a particular god or group of gods.

In many cases, people who share cultural backgrounds also share religious beliefs. For example, the major ethnicities of East Asia include the Han, Yamato, and Korean. The Han are a religiously diverse group whose beliefs derived from Chinese folklore. The Yamato, on the other hand, is divided into two major religious groups: Buddhism and Shintoism. And finally, like the Yamato, the Koreans are a religious plurality, or an ethnic group with diverse religious beliefs. (G12a)

Sample Items 7–8

Item 7

Why does Western China have one of the lowest population densities of Eastern Asia?

- A. The arid land makes agriculture difficult.
- B. The nearby large bodies of water are unhealthy.
- C. The islands are too rocky for home construction.
- D. The swampy marshes are hard to travel through.

Item 8

Look at the chart.

Country	Form of Government
The Republic of India	Federal Republic
The People's Republic of China	Oligarchy
Japan	Constitutional monarchy

Which conclusion can be drawn from the information in this chart?

- A. Political power in India is shared between the central and regional governments.
- B. The economy of India is more heavily regulated than the economy of Japan.
- C. China has a single leader who is democratically elected.
- D. Japan is ruled by an emperor.

Unit 6: Impact of Environment and Economy on Southern and Eastern Asia

In this unit, you will look at the economic climate of Southern and Eastern Asia. You will look at trade between the countries in this area and the influence of entrepreneurship and the importance of currency exchange. You will also study the impact that the environment has on this area, taking a look at flooding along waterways, pollution of the Ganges and Yangtze Rivers, and air pollution in China and India.

KEY TERMS

Air pollution in China and India: The burning of fossil fuels and car and factory emissions are polluting China's and India's air, resulting in damage to buildings, natural locations, and human health. (G10b)

Capital: The property (buildings, machinery, etc.) and technology that represent the economic investments of a person or business. (E10b)

Command economy: An economic system in which what is produced, how it is produced, and for whom it is produced is determined by the government. North Korea has a command economy. (E8a, c)

Currency exchange: A business that allows individuals or groups to exchange the currency of one country for that of another. The exchange of currencies is necessary in a world where trade takes place between nations with different monetary systems. (E9c)

Embargo: An official ban, usually on trade with another country. Sometimes the ban is on specific goods. (E6b)

Entrepreneurship: The process of starting an organization or business. The economies of many countries are supported by small businesses begun by entrepreneurs. (E10d)

Flooding in China and India: Because parts of China and India are located along waterways, they are subject to flooding, which can damage the soil and make areas practically uninhabitable. (G10b)

Ganges River pollution: The Ganges River serves 500 million people, most of whom believe it is of religious significance. As a result, many people bathe in the river, which contributes to the pollution. Cities along the river also discharge industrial waste into the water. (G10a)

Human capital: The human knowledge, creativity, and habits that contribute to an economy. (E10a)

Market economy: An economic system in which what is produced, how it is produced, and for whom it is produced is based on supply and demand. Producers set the prices for their goods based on what individuals are willing to pay. (E8a, c)

Mixed economy: An economy that is part market economy and part command economy. Most countries have mixed economies. (E1b,c)

Natural resources of Asia: Many parts of China, Indonesia, and Malaysia are heavily forested. In these regions, timber is a major resource. Fishing and agriculture are also major industries in Southern and Eastern Asia. In parts of Eastern Asia, particularly in China, mining is also an important industry. (E10c)

Quota: A limit set on the production of a product. Quotas can be set by governments or industry groups, such as OPEC. Its purpose is usually to control the price of a product and protect domestic production. (E9b)

Specialization: The focusing of a business or country on one or a relatively small number of products or services. Because most areas can produce only a limited number of goods or services, they must then trade these goods and services for others that they need. (E9a)

Tariff: A tax or duty that must be paid on a specific import or export. Tariffs are often used by governments to limit imports from other countries. (E9b)

Traditional economy: An economic system in which what is produced, how it is produced, and for whom it is produced is based on the traditions, beliefs, and customs of society. Traditional economies are usually agriculturally based. (E8a)

Voluntary trade: An economic market in which individuals and businesses are allowed to buy from and sell to whom they choose. A benefit of such an exchange is that most parties gain something they want from it. (E9a)

Yangtze River pollution: Pollution in the river has increased over 73% in the past 50 years. Most agree the pollution is caused by large-scale industrial and domestic development, as well as agricultural runoff. Hundreds of cities located along the river contribute to the pollution. (G10a)

Sample Items 9–10

Item 9

Which of these is the result of the pollution of the Ganges River?

- A. decreased fresh air
- B. increased tourism
- C. increased disease
- D. decreased taxes

Item 10

Which of these would occur in a country with a command economy?

- A. The market decides what to produce.
- B. The consumers help determine what to produce.
- C. The traditions of the country determine how to produce goods.
- D. The government of the country regulates how to produce goods.

Unit 7: Historical Background for Southern and Eastern Asia

In this unit, you will examine the historical background of Southern and Eastern Asia. In particular, you will learn about China’s Cultural Revolution, Gandhi’s movement for peace, China’s Great Leap Forward, nationalism, and some of the wars and conflicts in the area.

KEY TERMS

China’s Cultural Revolution: A radical movement in Chinese society and politics, led by Mao Zedong, that increased military rule and brought major changes to education. The government became more oppressive, free speech was severely limited, and people deemed enemies of the government were executed. (H3d)

Mohandas Gandhi: The leader of India’s revolution against Britain. A believer in nonviolent protests, Gandhi’s movement of peace led not only to India’s freedom but also influenced Martin Luther King, Jr., in the United States during the Civil Rights Movement. (H3b)

Great Leap Forward: An attempt by the government of China (1959–1960) to solve the nation’s economic woes by embracing industrialization. (H3d)

Korean War: In 1950, North Korean troops, aided by China, sought to invade and annex South Korea. The United Nations—and the United States in particular—feared the spread of communism and sent troops to prevent the annexation. (H3e)

Mao Zedong: Communist leader of China who led reforms that resulted in mass starvation and a weakening of the nation’s economy. Free speech and artistic expression also suffered under his reign. In the 1970s, he began to open China to the West. He died in 1976. (H3d)

Nationalism: A feeling of extreme pride in one’s own country; patriotism. This feeling led citizens of India and Vietnam to rebel against the foreign governments that occupied their countries—Great Britain in India and French Indo-China in Vietnam. (H3a)

Tiananmen Square: A public area in Beijing, China, where, in 1989, an estimated 2,000 student protestors were shot and killed by troops loyal to the Communist government. (H3d)

Vietnam: A nation in Southeast Asia located along the South China Sea. For many years it was divided into North and South Vietnam. When North Vietnam attempted to overthrow the South Vietnamese government, the United States entered the conflict, which became known as the Vietnam War. When South Vietnam collapsed in 1975, the two countries were reunited. (H3e)

KEY IDEA

Japan after World War II

At the end of World War II, much of Japan's infrastructure was in ruins. Industry had been destroyed, roads and bridges were in rubble, and several cities had been practically wiped off the map.

From 1945 until 1952, the United States occupied Japan, helping it to rebuild. The primary reason for this was that the U.S. wanted to create a civil and peaceful society. To that end, it helped the nation institute a democratic system allowing the Japanese people to elect their own leaders.

Censorship was abolished and freedom of speech guaranteed. Industry was rebuilt as a means of providing the Japanese people with the resources they needed to feed themselves, thus lessening the cost to the Allied Powers.

Today, Japan is a thriving nation with a large population. It is an active participant in world affairs, and it has provided many technological advances used the world over. (H3c)

Sample Items 11–12

Item 11

Why did the United States become involved in the wars in Korea and Vietnam?

- A. to help European countries retain their colonies
- B. to protect these countries from Japanese imperialism
- C. to stop the spread of communism throughout Asia
- D. to prevent conflicts in Asian countries from erupting into genocide

Item 12

Which event characterized the Cultural Revolution in China?

- A. war between Communists and Nationalists
- B. attacks on western influences in China
- C. modernization of Chinese agriculture
- D. protests in Tiananmen Square

Unit 8: Africa Today

In this unit, you will study Africa today—its geography, its governments, its religions, and the state of education today. You will learn about autocracy, confederation, democracy, and oligarchy. You will study the Congo, Nile, and Niger Rivers, the Kalahari and Sahara Deserts, the Atlas Mountains, and Lakes Tanganyika and Victoria. You will see the contrast between life on the savanna and in the tropical rainforest. You will learn about countries like Kenya, Nigeria, Sudan, and South Sudan.

Africa



KEY TERMS

Atlas Mountains: A mountain chain in northwestern Africa. (G1a)

Autocracy: A system in which all of the power is held by one person. In this system of government, the ruler has absolute or unlimited power. (CG1b)

Confederation: A group of states or nations that retain most power while granting limited authority to a central government. (CG1a)

Democracy: A system of government in which a nation's citizens vote for their leaders. (CG1b)

Democratic Republic of the Congo (Zaire): A nation in Central Africa that first gained independence from Belgium in 1960. (G1b)

Education in Kenya and Sudan: Many people in these African nations believe that women should stay home and care for children; therefore, girls are not sent to school. Poverty also places limits on the education of children. (CG3a)

Egypt: A country in northeastern Africa on the Mediterranean Sea. (G1b)

Ethnic group: A group of people of common descent or who share a cultural background. (G4a)

Federal system of government: A system in which individual states share authority with a central government. (CG1a)

Government stability: In Africa, many nations do not have stable governments. Wars and rebellions are frequent. As a result, it is hard to funnel needed funding toward fighting diseases such as AIDS and solving problems such as famine. (CG2b)

Kenya: A country in east-central Africa situated on the Indian Ocean. (G1b)

Literacy rates in Africa: The literacy rates in Africa are generally the lowest in the world, with Sub-Saharan Africa having the lowest in all of Africa. As a result, employment rates and the standard of living in those regions are also low. (G4c)

Nigeria: A nation in Western Africa situated on the Gulf of Guinea. (G1b)

Oligarchy: A system in which a small and powerful group controls the government. (CG1b)

Parliamentary system of government: A democratic form of government in which voters choose representatives to a governing body called a parliament. Kenya and South Africa are governed under a parliamentary system. (CG1c, CG2a)

Presidential system of government: A republican form of government in which voters choose a president to lead the executive branch of government, which is separate from other branches. (CG1c)

Religion in Africa: There are a number of religions in Africa. The Ashanti people in Northern Africa and the Bantu of Central and Southern Africa hold beliefs centered on African tribal myths. (G4b)

Religious group: A group of people who share an organized system of beliefs centered on a particular god or group of gods. (G4a)

Sahel: A region south of the Sahara Desert, in north-central Africa. It is inhabited by small nomadic groups of farmers. (G1a, G3a)

South Africa: A nation located at the southern tip of Africa, on both the Atlantic and Indian Oceans. (G1b)

South Sudan: A nation in northeastern Africa. It was part of Sudan until 2011, when its inhabitants voted for independence. (G1b)

Sudan: A country in northeast Africa. (G1b)

Unitary system of government: A system in which an entire country is ruled by a single government. Power is not shared between the central government and smaller states as it is in a federal system. (CG1a)

Physical Map of Africa



Congo River: A river in Central Africa that begins in Zambia and empties into the Atlantic Ocean. (G1a)

Kalahari Desert: A large desert in southwestern Africa, most of which is in Botswana. (G1a)

Lake Tanganyika: The longest lake in the world. It is located in the Great Rift Valley of Central Africa, between Tanzania and Congo. (G1a)

Lake Victoria: The second largest freshwater lake in the world and the largest in Africa. (G1a)

Niger River: A river in Western Africa that begins in Guinea and flows into the Gulf of Guinea. (G1a)

Nile River: The world's longest river. It is longer than the entire width of the United States. It flows through East Africa and empties into the Mediterranean. It was also the site of the world's first major civilization. (G1a)

Sahara: The world's largest desert. Located in Northern Africa, it is largely uninhabited. (G1a, G3a)

Savanna: A grassland in a tropical or semi-tropical area. Africa is home to many savannas. Large portions of them are national parks and wildlife refuges. (G1a, G3a)

Tropical rainforest: A forest where it rains nearly every day. They are located mainly in the central section of Africa. Outlying areas of tropical rainforests tend to be the most populated, thanks to their rainfall and vegetation. (G1a, G3a)

Sample Items 13–14

Item 13

Which type of government provides the MOST personal freedoms for its citizens?

- A. autocratic
- B. monarchic
- C. oligarchic
- D. democratic

Item 14

How has government instability affected the fight against AIDS in Africa?

- A. It has delayed research into development of an AIDS vaccine.
- B. It has made it more difficult to raise money to fight the disease.
- C. It has made it difficult to deliver medical assistance to the victims of the disease.
- D. It has prevented health workers from learning of the existence of AIDS on the continent.

Unit 9: Impact of Environment and Economy on Africa

In this unit, you will look at the economic and environmental issues facing African nations. You will learn about the problem of water pollution, desertification, and soil erosion. You will examine trade embargos, mixed economies, and quotas.

KEY TERMS

Capital: The property (buildings, machinery, etc.) and technology that represent the chief investments of a person or business. (E3b)

Command economy: An economic system in which what is produced, how it is produced, and for whom it is produced is determined by the government. (E1a)

Currency exchange: A business that allows individuals or groups to exchange the currency of one country or place for that of another. The exchange of currencies is necessary in a world where trade takes place between nations with different monetary systems. (E2b)

Desertification: The process by which various types of land become desert. In Africa, the overgrazing of animals and severe droughts have led to desertification. (G2c)

Embargo: An official ban, usually on trade with another country. Sometimes the ban is on specific goods. (E2a)

Entrepreneurship: The process of starting an organization or business. The economies of many countries are supported by small businesses begun by entrepreneurs. (E3d)

Market economy: An economic system in which what is produced, how it is produced, and for whom it is produced is based on supply and demand. Producers set the prices for their goods based on what individuals are willing to pay. (E1a, c)

Mixed economy: An economy that is part market economy and part command economy. Most countries have mixed economies. (E1b,c)

Natural resources in Africa: Africa has a number of natural resources, including uranium, oil, diamonds, and gold. Over the years, industries have built up around these resources. Some areas, such as Nigeria and South Africa, have an abundance of such resources and have stronger economies and higher standards of living in comparison to most nations in Africa. (E3c)

Soil: In Sub-Saharan Africa, deforestation has led to soil erosion. Without the nutrients that trees leave behind in the ground, the land is difficult to farm. (G2b)

Specialization: The focusing of a business or country on one or a relatively small number of products or services. Because most areas can produce only a limited number of goods or services, they must then trade these goods and services for others that they need. (E2a)

Tariff: A tax or duty that must be paid on a specific import or export. Tariffs are often used by governments to limit imports from other countries. (E2a)

Traditional economy: An economic system in which what is produced, how it is produced, and for whom it is produced is based on the traditions, beliefs, and customs of society. Traditional economies are usually agriculturally based. (E1a)

Voluntary trade: An economic market in which individuals and businesses are allowed to buy from and sell to whom they choose. A benefit of such an exchange is that most parties gain something they want from it. (E6a)

Water pollution: In many parts of Africa, waste from humans and industry has contaminated most bodies of freshwater, leaving as much as 50% of the population without drinking water. There is also unequal distribution of water, with irrigation moving freshwater into places with greater wealth and more industry. (G2a)

Sample Items 15–16

Item 15

Which of these is a likely difference between the way people live in the Sahel and the way people live in the rainforest?

- A. More people in the Sahel make their living as nomadic herders.
- B. The people of the rainforest are more likely to live near rivers.
- C. The people of the Sahel are more likely to live in large cities.
- D. More people in the rainforest make their living as traders.

Item 16

Which of these examples highlights the advantages of international currency systems?

- A. A loaf of bread costs the same in South Africa as it does in Nigeria.
- B. A tourist is charged the same amount of sales tax in Nigeria as in Kenya.
- C. An army in Sudan is less likely to declare war on a neighboring country such as Ethiopia.
- D. A Kenyan tradesperson knows how much money is needed to buy a product sold in South Africa.

Unit 10: Connecting Africa’s Past with Africa’s Present

In this unit, you will look at Africa’s past and present. You will study the partitioning of Africa by European nations, the apartheid policy that kept Africa segregated, and nationalistic pride. You will learn about two important South African historical figures, F. W. de Klerk and Nelson Mandela.

KEY TERMS

Apartheid: A government-mandated policy of racial segregation that kept white people in power in South Africa. It began shortly after World War II, in 1948, and lasted until 1994. (H1c)

F. W. de Klerk: The last state president of South Africa, he helped broker the end of apartheid and usher in democratic elections. (H1c)

Nelson Mandela: An outspoken statesman in South Africa who opposed apartheid. His work to end the system landed him in prison; when he was freed, he became the first black, democratically elected president of the nation. (H1c)

Nationalism: A feeling of pride in one’s own country; patriotism. This feeling led natural-born citizens of South Africa, Kenya, and Nigeria to rebel against foreign occupation, install their own governments, and control their own natural resources. (H1b)

Pan-African Movement: A movement aimed at uplifting people of African descent by rallying support and solidarity worldwide. (H1d)

KEY IDEA

Europe Partitions Africa

Toward the end of the 19th century, European nations vied for control over various regions of Africa. They wanted jurisdiction over the continent’s ample natural resources.

To avoid warring amongst themselves, the nations of Europe agreed to partition Africa based on their own needs and desires. They created new boundaries between previous existing regions and in some cases created entirely new regional boundaries, which they occupied.

The partitioning of Africa began at the Berlin Conference in 1884. By 1914, only Liberia and what is today known as Ethiopia remained independent. The other 90% of the continent remained under European control.

When the nations of Europe finally gave up control of Africa, the artificial boundaries they had created led to civil wars, ethnic conflict, and political instability. (H1a)

Sample Items 17–18

Item 17

What was one of the effects of the European partitioning of Africa?

- A. It revived the slave trade in West Africa.
- B. It allowed the development of African resources.
- C. It ignored ethnic and religious boundaries, fueling conflicts.
- D. It separated religious groups, promoting stability across the continent.

Item 18

How did Nelson Mandela influence the end of apartheid in South Africa?

- A. He directed protests that forced the end of apartheid.
- B. He supported legislation that delayed the end of apartheid.
- C. He served as the last president of South Africa under apartheid and helped bring it to an end.
- D. He spoke publically of his fears that the end of apartheid would bring civil war in South Africa.

Unit 11: Your Financial Future

In this unit, you will focus on personal finance. You will take a look at credit, income, savings, and spending. You will learn about the risks of investments.

KEY TERMS

Credit: The ability of a consumer to obtain a good or service with the payment to come in the future. (E4)

Income: The money a person earns through work or investments. (E4)

Investment: The placing of money in a share, property, scheme, or commercial venture with the expectation that it will earn more money in the future, though the possibility always exists that it will be lost. (E4)

Savings: Money a person or institution sets aside so that it will accumulate and/or earn interest. (E4)

Spending: Money a person uses in order to obtain something. (E4)

Sample Items 19–20

Item 19

Which of these is an example of credit?

- A. William buys a new pair of sneakers.
- B. Samantha takes out a loan to pay her college tuition.
- C. Miguel charges \$3 each for his custom bumper stickers.
- D. Tameka earns \$9 an hour working at a local coffee shop.

Item 20

Gloria deposits money into the bank to buy a car in the future. What is this action an example of?

- A. credit
- B. income
- C. saving
- D. spending

SOCIAL STUDIES ADDITIONAL SAMPLE ITEM KEYS

Item	Standard/ Element	DOK Level	Correct Answer	Explanation
1	SS7G8c	2	A	The correct answer is choice (A) All worship one god. Choice (B) is not correct because Christianity does not forbid the consumption of pork. Choice (C) is not correct because Jews do not consider Jesus a prophet. Choice (D) is not correct because only Muslims are required to make a pilgrimage to Mecca.
2	SS7G5a	1	D	The correct answer is choice (D) Suez Canal. Choices (A), (B), and (C) are not the feature indicated on the map.
3	SS7E7c	3	B	The correct answer is choice (B) Saudi Arabia's GDP per capita is the result of its high production of oil. Saudi Arabia's high per capita is due to its high production of oil. The conclusions in choices (A), (C), and (D) cannot be supported by this chart.
4	SS7E6c	2	A	The correct answer is choice (A) to control the price of oil. Choices (B), (C), and (D) are not related to the production of oil, which is OPEC's main concern.
5	SS7H2b	2	A	The correct answer is choice (A) the Holocaust. Choices (B), (C), and (D) are all events that are unrelated to the founding of Israel.
6	SS7H2c	2	A	The correct answer is choice (A) The area contains holy sites for three of the world's major religions. Choices (B), (C), and (D) are not true of Southwest Asia (Middle East).
7	SS7G11b	2	A	The correct answer is choice (A) The arid land makes agriculture difficult. Choices (B), (C), and (D) do not describe the geographic realities of desert-like Western China.
8	SS7CG7a	2	A	The correct answer is choice (A) Political power in India is shared between the central and regional governments. The conclusion in choice (B) is based on economic systems, not governments, and is not supported by this chart. Choice (C) does not accurately describe a communist state. Choice (D) describes a monarchy, not a constitutional monarchy.
9	SS7G10a	2	C	The correct answer is choice (C) increased disease. Choice (A) is untrue because the fresh air is not affected. Choice (B) is incorrect because pollution would not increase tourism. Choice (D) is incorrect because pollution would not reduce taxes.

Item	Standard/ Element	DOK Level	Correct Answer	Explanation
10	SS7E8a	1	D	The correct answer is choice (D) The government of the country regulates how to produce goods. In a command economy, the government of the country answers the questions of (1) what to produce, (2) how to produce, and (3) for whom to produce. Choice (A) is incorrect because it is an example of what would occur in a market economy. Choice (B) is incorrect because it is an example of what would occur in a mixed economy. Choice (C) is incorrect because it is an example of what would occur in a traditional economy.
11	SS7H3e	2	C	The correct answer is choice (C) to stop the spread of communism throughout Asia. Choices (A), (B), and (D) were not concerns of the United States.
12	SS7H3d	1	B	The correct answer is choice (B) attacks on western influences in China. Choices (A), (C), and (D) describe other eras in Chinese history.
13	SS7CG1b	2	D	The correct answer is choice (D) democratic. Choices (A), (B), and (C) are all examples of systems of government that offer fewer personal freedoms to their citizens.
14	SS7CG3b	3	C	The correct answer is choice (C) It has made it difficult to deliver medical assistance to the victims of the disease. Choices (A), (B), and (D) are not results of government instability in Africa.
15	SS7G3a	2	A	The correct answer is choice (A) More people in the Sahel make their living as nomadic herders. Choices (B), (C), and (D) are just as likely for people of the Sahel as for people of the rainforest.
16	SS7E2b	2	D	The correct answer is choice (D) A Kenyan tradesperson knows how much money is needed to buy a product sold in South Africa. Choice (A) is incorrect because the exchange rate does not determine the price of basic commodities. Choices (B) and (C) are incorrect because exchange rates do not affect sales tax rates or government's decisions to go to war.
17	SS7H1a	2	C	The correct answer is choice (C) It ignored ethnic and religious boundaries, fueling conflicts. Choices (A), (B), and (D) are not effects of the European partitioning of Africa.

Item	Standard/ Element	DOK Level	Correct Answer	Explanation
18	SS7H1c	3	A	The correct answer is choice (A) He directed protests that forced the end of apartheid. Choices (B), (C), and (D) do not accurately portray Nelson Mandela's role as a leader in the anti-apartheid movement.
19	SS7E4	2	B	The correct answer is choice (B) Samantha takes out a loan to pay for her college tuition. Choice (A) is an example of spending. Choices (C) and (D) are examples of income.
20	SS7E4	2	C	The correct answer is choice (C) saving. Choices (A), (B), and (D) do not describe the provided saving scenario.

ACTIVITY

The following activity develops skills in the following units: Unit 2: Southwest Asia (Middle East) Today; Unit 5: Southern and Eastern Asia Today; and Unit 8: Africa Today.

Standards: SS7G1, SS7G3, SS7G5, SS7G7, SS7G9, SS7G11

Connecting Geography, Resources, and Population

You will examine thematic maps to determine connections between natural resources, physical geography, and population distribution in the three regions studied. This activity can be completed multiple times, focusing on a different region each time.

- I. Choose one of the three regions studied:
Africa, Southwest Asia, East and South Asia
Option: Divide East Asia from South Asia and study each area separately.

- II. Answer the following questions:
 1. What are the major land features of the region?
 2. What are the major bodies of water and rivers of the region?
 3. What natural resources are found in the region? Where are they found?
 4. Where are the areas of high population density? Where are the areas of low population density?

- III. Draw a conclusion based on one of the questions below:
 1. What connections can you find between the locations of major bodies of water and rivers and the population density of these locations?
 2. What connections can you find between the locations of major land features and the population density of these locations?
 3. What connections can you find between the locations of natural resources and population density?
 4. What connections can you find between the locations of land features, bodies of water and rivers, and the locations of natural resources?

- For example, you might note that areas with deserts in Africa have low population densities.

- IV. Now answer the following questions. Each question should have more than one answer.
 1. What connections can you find between the locations of major bodies of water and rivers and the population density of these locations?
 2. What connections can you find between the locations of major land features and the population density of these locations?
 3. What connections can you find between the locations of natural resources and population density?
 4. What connections can you find between the locations of land features, bodies of water and rivers, and the locations of natural resources?

- V. Share your conclusions with a family member or friend.

ACTIVITY

The following activity develops skills in the following units: Unit 2: Southwest Asia (Middle East) Today; Unit 5: Southern and Eastern Asia Today; and Unit 8: Africa Today.

Standards: SS7CG1, SS7CG2, SS7CG4, SS7CG5, SS7CG6, SS7CG7

This activity can be completed multiple times, focusing on a different country each time.

Forms of Government

Form of Government	
Who is/are the leader(s)	
How the leader(s) is/are selected	
Role of the citizen in terms of voting rights and personal freedom	
Other important information	

1. Choose a country specifically listed in the standards (for example, Nigeria, South Africa, Iran, Israel, India, Japan, or North Korea).
2. Using the Internet or other resource materials, research the form of government for the country you chose.
3. As you draw conclusions about the form of government for the country you chose, complete the chart provided.
4. Share your findings with a family member or friend.

APPENDIX A: LANGUAGE PROGRESSIVE SKILLS, BY GRADE

The following skills, marked with an asterisk (*) in Language standards 1–3, are particularly likely to require continued attention in higher grades as they are applied to increasingly sophisticated writing and speaking.

Standard	Grade(s)							
	3	4	5	6	7	8	9–10	11–12
L.3.1f. Ensure subject-verb and pronoun-antecedent agreement.								
L.3.3a. Choose words and phrases for effect.								
L.4.1f. Produce complete sentences, recognizing and correcting inappropriate fragments and run-ons.								
L.4.1g. Correctly use frequently confused words (e.g., <i>to/too/two; there/their</i>).								
L.4.3a. Choose words and phrases to convey ideas precisely.*								
L.4.3b. Choose punctuation for effect.								
L.5.1d. Recognize and correct inappropriate shifts in verb tense.								
L.5.2a. Use punctuation to separate items in a series.†								
L.6.1c. Recognize and correct inappropriate shifts in pronoun number and person.								
L.6.1d. Recognize and correct vague pronouns (i.e., ones with unclear or ambiguous antecedents).								
L.6.1e. Recognize variations from standard English in their own and others' writing and speaking, and identify and use strategies to improve expression in conventional language.								
L.6.2a. Use punctuation (commas, parentheses, dashes) to set off nonrestrictive/parenthetical elements.								
L.6.3a. Vary sentence patterns for meaning, reader/listener interest, and style.‡								
L.6.3b. Maintain consistency in style and tone.								
L.7.1c. Places phrases and clauses within a sentence, recognizing and correcting misplaced and dangling modifiers.								
L.7.3a. Choose language that expresses ideas precisely and concisely, recognizing and eliminating wordiness and redundancy.								
L.8.1d. Recognize and correct inappropriate shifts in verb voice and mood.								
L.9-10.1a. Use parallel structure.								

* Subsumed by L.7.3a

† Subsumed by L.9-10.1a

‡ Subsumed by L.11-12.3a

APPENDIX B: CONDITION CODES

The student response is flawed for various reasons and will receive a condition code. Students who receive a condition code have a score of zero (0).

- For the extended writing tasks, both traits receive a score of 0. For Trait 1: Ideas 0 out of 4 possible points and for Trait 2: Language Usage 0 out of 3 points. (Or 0 points out of a possible 7 points.)
- For the narrative item, the score is 0 out of a possible 4 points.

CODE	Performance Scoring: Code Description	Full Description
A	Blank	<ul style="list-style-type: none"> • Blank • Student's response did not contain words. • In some instances, student may have drawn pictures.
B	Copied	<ul style="list-style-type: none"> • Student's response is not his/her own work. • Student does not clearly attribute words to the text(s). • Student copies from the text(s) that serve as writing stimulus.
C	Too Limited to Score/ Illegible/ Incomprehensible	<ul style="list-style-type: none"> • Student's response is not long enough to evaluate his/her ability to write to genre or his/her command of language conventions. • Response is not able to be deciphered. • An illegible response does not contain enough recognizable words to provide a score. • An incomprehensible paper contains few recognizable English words or it may contain recognizable English words arranged in such a way that no meaning is conveyed.
D	Non-English/ Foreign Language	<ul style="list-style-type: none"> • Written in some language other than English. • The writing items/tasks on the test require the student to write in English.
E	Off Topic/Off Task/ Offensive	<ul style="list-style-type: none"> • Student may have written something that is totally off topic (e.g., major portion of response is unrelated to the assigned task). • Student response did not follow the directions of the assigned task (i.e., off task). • Student uses inappropriate or offensive language/picture.

Study/Resource Guide
for Students and Parents
Grade 7
End-of-Grade

